

# Shielding Systems

**Objective:** To reinforce awareness about safe use of trench shielding systems.

Unlike traditional shoring systems, which directly support trench walls, **shielding systems**, also called **trench boxes**, are intended to protect employees from cave-ins and other similar events.

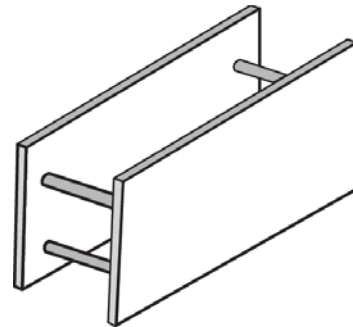

## Safety Guidelines:

- Refer to the manufacturer's tabulated data when planning shielding system use.
- **Shielding systems are only to be used for employee protection**, and are not intended for use as a shoring system or direct support of trench walls.
- Keep the space between the outside of the shielding system and the trench wall as small as possible. Never subject a shielding system to loads exceeding its rated capacity.

## Installation:



**Always** consult manufacturer documentation before installing boxed systems.

- Install all boxed systems (shielding systems or boxed shoring systems) from the top down.
- Remove all boxed systems from the bottom up.
- Never move a shielding system until all employees are clear from the shielding system and trench.
- Never stack shields unless they have been specifically designed to be stacked.
- Never stack shields from different manufacturers, as their connection points may not be compatible.

# Shielding Systems

## Slope and Box Combinations

The maximum depth for a combination slope and box system is 20 feet.

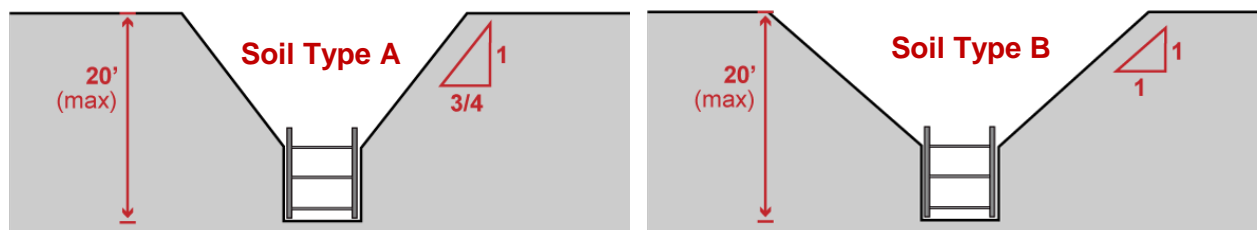

When using sloping in combination with a trench box or shoring box, confirm that the slope does not surpass the maximum angle of repose for the soil classifications.

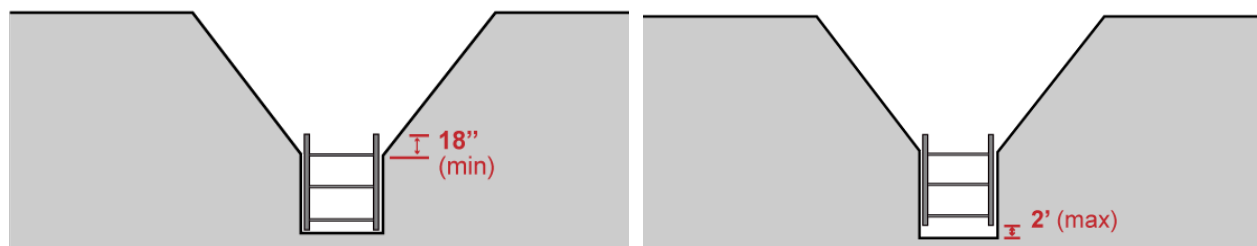

If there is sloping above the boxed system, the top should **extend at least 18 inches** above the level of any materials that could cave or roll into the trench.

The shielding system does not always need to reach the bottom of the excavation.

Excavations may extend **up to 2 feet below** the shielding system if these conditions are met:

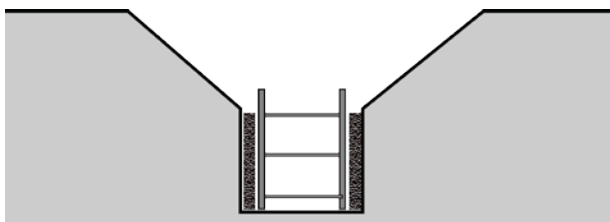

The forces of a cave-in can literally push a box sideways, causing a crushing hazard. After a box is positioned for the work, **fill the voids** between the box and the trench wall with excavated material to prevent displacement caused by a cave-in.

1. The shield is rated to withstand the forces presented by the full depth of the trench.
2. The bottoms of the trench walls show no signs of weakening.
3. The trench and surrounding area is closely monitored for danger signs like bulging, heaving, or boiling and for features that may affect the trenches stability, such as adjacent structures or vibration sources.

# Shielding Systems

This form documents that the training specified above was presented to the listed participants. By signing below, each participant acknowledges receiving this training.

Organization: \_\_\_\_\_ Date: \_\_\_\_\_

Trainer: \_\_\_\_\_ Trainer's Signature: \_\_\_\_\_

**Class Participants:**

Name: \_\_\_\_\_ Signature: \_\_\_\_\_

Name: \_\_\_\_\_ Signature: \_\_\_\_\_

Name: \_\_\_\_\_ Signature: \_\_\_\_\_

Name: \_\_\_\_\_ Signature: \_\_\_\_\_

Name: \_\_\_\_\_ Signature: \_\_\_\_\_

Name: \_\_\_\_\_ Signature: \_\_\_\_\_

Name: \_\_\_\_\_ Signature: \_\_\_\_\_

Name: \_\_\_\_\_ Signature: \_\_\_\_\_

Name: \_\_\_\_\_ Signature: \_\_\_\_\_

Name: \_\_\_\_\_ Signature: \_\_\_\_\_

Name: \_\_\_\_\_ Signature: \_\_\_\_\_

Name: \_\_\_\_\_ Signature: \_\_\_\_\_

Name: \_\_\_\_\_ Signature: \_\_\_\_\_

Name: \_\_\_\_\_ Signature: \_\_\_\_\_

Name: \_\_\_\_\_ Signature: \_\_\_\_\_

Name: \_\_\_\_\_ Signature: \_\_\_\_\_

*Remember to document attendance in the Training Track application of the Risk Management Center.*