



McWilliams School of
Biomedical Informatics

The Aorta Is Open Source

- Future of AI in Healthcare

Jiajie Zhang, PhD, Dean

Glassell Family Foundation Distinguished Chair in Informatics Excellence

March 6, 2026

Learning Objectives

- Understand how AI transforms cognitive work by reducing time, scaling expertise, and lowering costs.
- Recognize how AI restructures—not just accelerates—cognitive work.
- Describe the foundations of an AI-native health science institution.

**The Internet flattened
the world of information.**

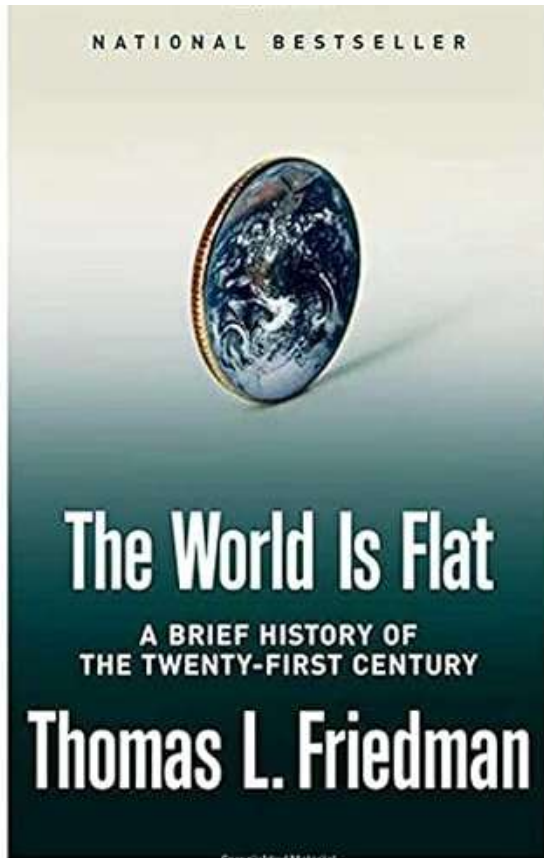

2005

**AI is now flattening the
world of intelligence**

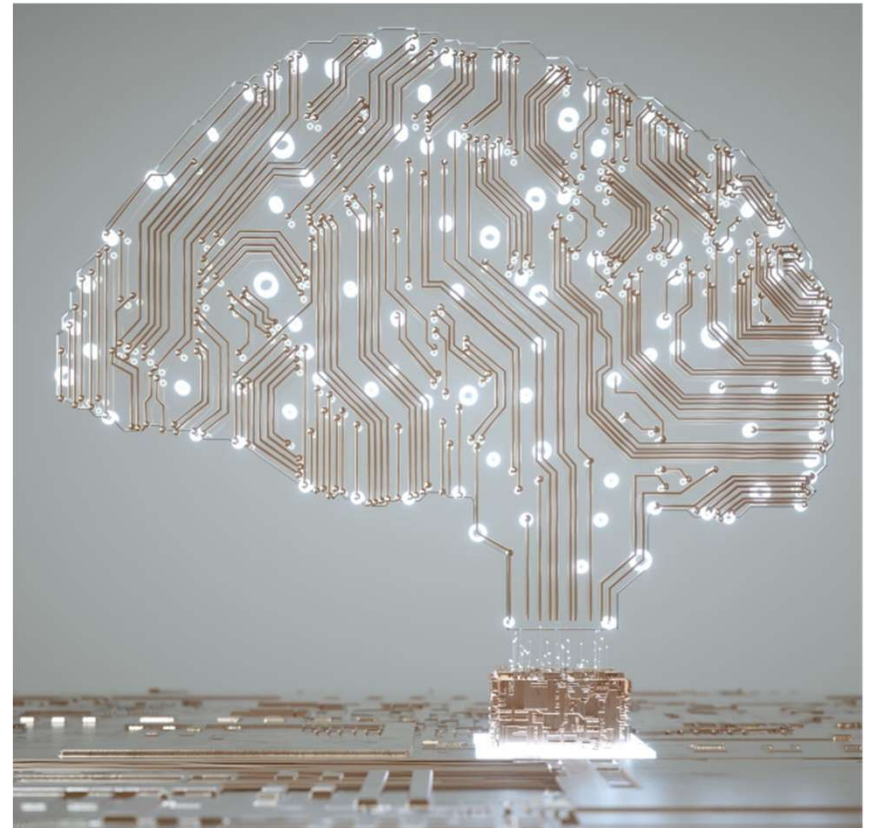

2025

The background of the slide is a dark blue, semi-transparent overlay of medical scan data. It features several axial brain slices, some with white lines indicating anatomical planes. Overlaid on this are various technical parameters and text in a light blue font, including 'FoV 199', '296*512', 'Sag(1.5)', 'Tra>Cor(6.1)', 'W 128', 'C 66', 'ASATI', '11/19', 'Chloro', 'Hemom', '4VA12', 'NES', 'STUDY 1', '16:41:56', '12 MAR 18', 'AF', '5cm', and 'R'.

The State of AI

- Intelligence is Shareable, Scalable, and Open Source

October 8 & October 9, 2024

AI has won Nobel Prizes



NOBELPRISET I FYSIK 2024
THE NOBEL PRIZE IN PHYSICS 2024

KUNGL. VETENSKAPS AKADEMIEN
THE ROYAL SWEDISH ACADEMY OF SCIENCES



John J. Hopfield
Princeton University, NJ, USA



Geoffrey E. Hinton
University of Toronto, Canada

"för grundläggande upptäckter och uppfinningar som möjliggör maskininläring med artificiella neuronnätverk"
"for foundational discoveries and inventions that enable machine learning with artificial neural networks"



NOBELPRISET I KEMI 2024
THE NOBEL PRIZE IN CHEMISTRY 2024

KUNGL. VETENSKAPS AKADEMIEN
THE ROYAL SWEDISH ACADEMY OF SCIENCES



David Baker
University of Washington
USA

"för datorbaserad protein design"
"for computational protein design"



Demis Hassabis
Google DeepMind
United Kingdom

"för proteinstrukturprediktion"
"for protein structure prediction"



John M. Jumper
Google DeepMind
United Kingdom

AI Wins the 2024 Nobel Prize in Physics

 **Jiajie Zhang**
McWilliams School of Biomedical Informatics at University of Texas Health Science Center at Houston



October 8, 2024

AI Wins Nobel Prize... Again!
Jiajie Zhang on LinkedIn • 3 min read
October 9, 2024 Jiajie Zhang, PhD Dean and Professor Glassell Family Foundation Distinguish...

April 20, 2025

AI could end disease in 10 years.

Demis Hassabis: 2024 Nobel Laureate in Chemistry

Latest ▾ Local News ▾ Live ▾ Shows ▾ ... CBS NEWS

60 MINUTES | Full Episodes | Overtime | 60 Minutes on Paramount+ | 60 Minutes Channel

60 MINUTES - NEWSMAKERS

Artificial intelligence could end disease, lead to "radical abundance," Google DeepMind CEO Demis Hassabis says

By Scott Pelley
April 20, 2025 / 6:57 PM EDT / CBS News

f X

April 16, 2025

AI could solve shortages of Doctors and Teachers.

Bill Gates says AI could solve shortages for 2 key professions

Lee Chong Ming
Apr 16, 2025 | 1:47 AM ET



April 16, 2025

AI will be as smart as the smartest artists in 3 to 5 years

EX-GOOGLE CEO ERIC SCHMIDT: AI THAT IS 'AS SMART AS THE SMARTEST ARTIST' WILL BE HERE IN 3 TO 5 YEARS

196 SHARES [Facebook] [Twitter] [LinkedIn] [Email]

APRIL 16, 2025 BY DANIEL TENCER



Eric Schmidt. Photo: Guillaume Paumier/Creative Commons

Former Google CEO Eric Schmidt says the world is three to five years away from "artificial general intelligence" that will be equal to, if not better, than any human thinkers or creators today.

LATEST M



January 7, 2025

AI will fundamentally change what we teach and learn at schools

LEADERSHIP > EDUCATION

AGI Is Coming In 2025. Schools Urgently Need A Strategy

By Dan Fitzpatrick, Contributor. Dan Fitzpatrick covers the intersection of ed... Follow Author

Jan 07, 2025, 07:00am EST

Share Save Comment 8



AGI Is Coming in 2025. Schools Urgently Need A Strategy CQ-ROLL CALL, INC VIA GETTY IMAGES

The CEO of OpenAI, Sam Altman, is confident that his team "know how to build AGI." In a blog post, he followed up by explaining that by the end of 2025, we may see the "first AGI agents" joining the workforce. This revelation signals another year of fast progress ahead for AI. AGI - Artificial General Intelligence - will likely effect every facet of human life, from the economy to education.

April 21, 2025

AI is transforming government

UAE first country to use AI to write laws

Gulf nation also plans to use technology for judicial rulings, as experts warn about its reliability

Melanie Swan

Related Topics
United Arab Emirates, Artificial Intelligence, Middle East, Sheikh Mohammed bin Rashid Al Maktoum

21 April 2025 3:04pm BST

🔖 19

🎁 Gift this article free

🗨️ 📧 📧 📧



Sheikh Mohammed bin Rashid al-Maktoum, centre, says that AI will make the process faster and more precise. Credit: Christopher Pike/Bloomberg

May 7, 2025

Most of your friends will be AI

THE WALL STREET JOURNAL

TECHNOLOGY

Zuckerberg's Grand Vision: Most of Your Friends Will Be AI

Meta's CEO is promoting a future where artificial intelligence is increasingly intertwined with people's lives



July 11, 2025

New jobs will be created;
some jobs will be lost;
every job will be transformed.

CNN Business Markets Tech Media Calculators Videos Watch Listen

WATCH LIVE

- Former CDC chief Susan Monarez testifies before Senate about her ouster and vaccine policy differences with RFK Jr.
- FBI Director Kash Patel testifies before House about Charlie Kirk shooting investigation and agency upheaval

Markets →			
DOW	46,074.45	0.69% ▲	
S&P 500	6,598.21	0.13% ▼	
NASDAQ	22,211.78	0.55% ▼	

Fear & Greed Index →

57 **Greedy** is driving the US market

Latest Market News →

- Trump's lawsuit against the New York Ti
- Jerry quits Ben & Jerry's
- What to expect from the most extraordi

Nvidia's Jensen Huang says AI could lead to job losses 'if the world runs out of ideas'

By Auzinea Bacon, CNN
3 min read · Published 5:06 PM EDT, Fri July 11, 2025

43 comments



AI Performance vs. Human Mean and Pass Thresholds on Health-Licensure Exams (mid-2025)

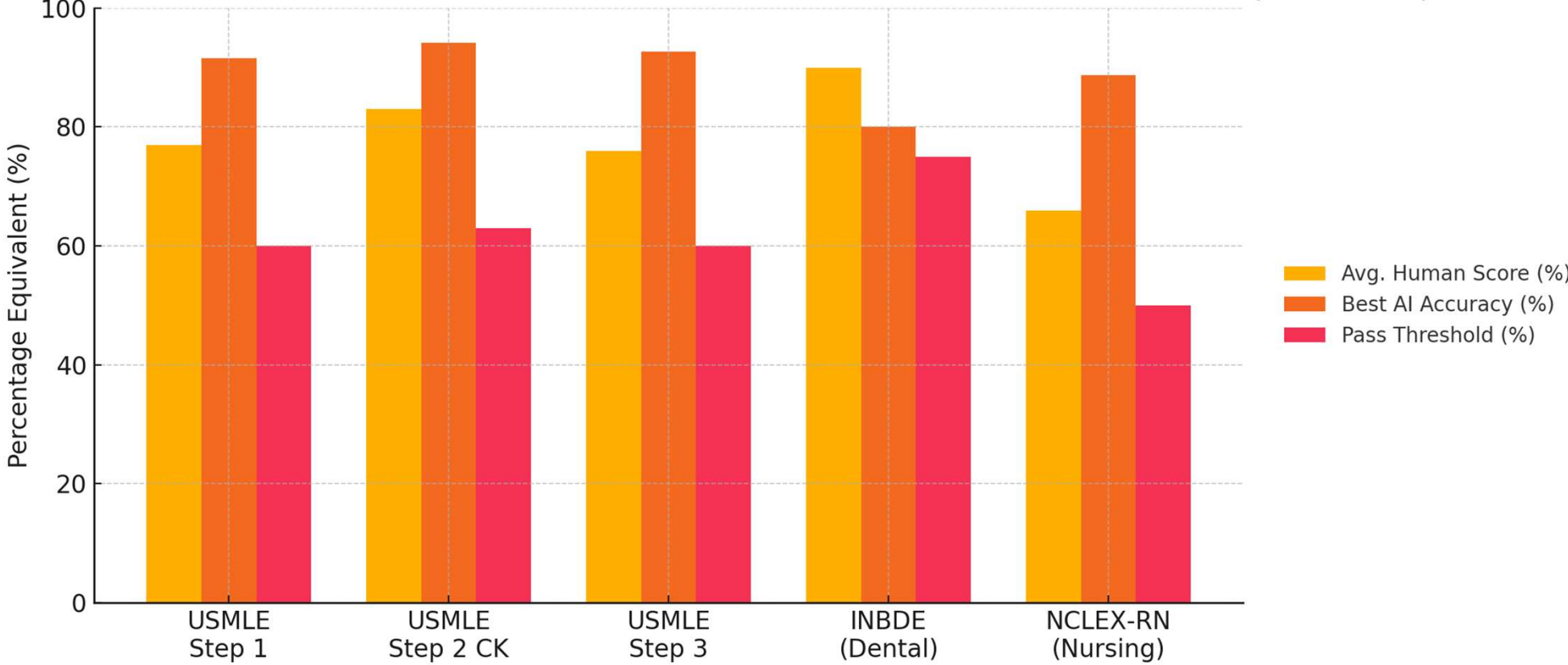

June 30, 2025

AI Panel Diagnoses 4x Better Than Doctors—And Cheaper

- Doctors work step-by-step to solve tough cases.
- MAI-DxO simulates a smart AI doctor panel.
- It chooses questions and tests wisely to reduce waste.
- Diagnoses correctly 4× more often than doctors.
- Spends half as much as typical AI or human methods.

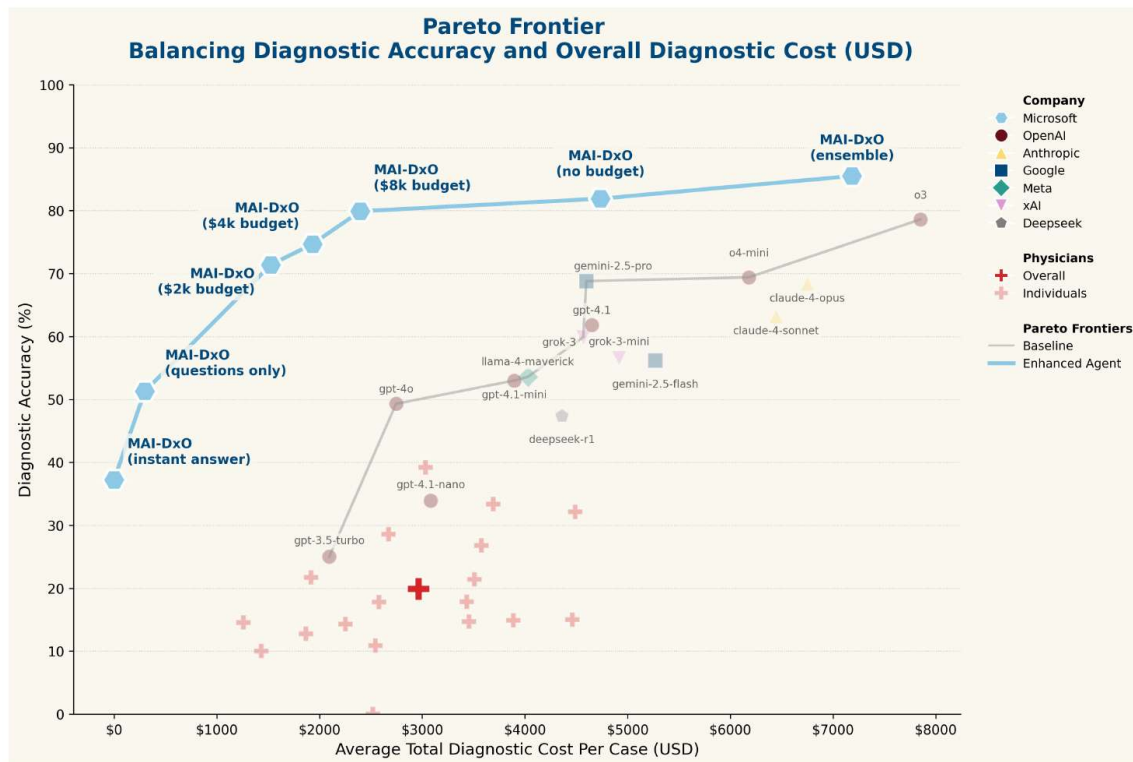

Figure 7: Pareto-frontier showing diagnostic accuracy versus average cumulative monetary cost for each agent. Off-the-shelf models were evaluated using a uniform baseline prompt (see Figure 4). MAI-DxO, built on top of the o3 model, achieves Pareto dominance over both off-the-shelf models and practicing physicians.

<https://arxiv.org/pdf/2506.22405v1>

AlphaFold



 NOBELPRISET I KEMI 2024
THE NOBEL PRIZE IN CHEMISTRY 2024

 KUNGL. VETENSKAPS
AKADEMIEN
THE SWEDISH ACADEMY OF SCIENCES

		
David Baker University of Washington USA	Demis Hassabis Google DeepMind United Kingdom	John M. Jumper Google DeepMind United Kingdom
"för datorbaserad proteindesign" "for computational protein design"	"för proteinstrukturprediktion" "for protein structure prediction"	

#NobelPrize

AI Wins Nobel Prize... Again!

Jiajie Zhang on LinkedIn • 3 min read

October 9, 2024 Jiajie Zhang, PhD Dean and Professor Glassell Family Foundation Distinguish...

iDFax

With iDFax, the only thing the human user needs to do is to verify (1) physician name; (2) patient name and DOB; (3) document type

(5) Automatic highlighting of DOB and Names for easy human verification

Dear Dr. Ejaz,

RE: Patient Referral - Harold Brownfax, DOB: 01/25/1959

I am writing to refer my patient, Mr. Harold Brownfax, who has been experiencing persistent back pain for the past [duration]. Despite initial conservative management including physical therapy and oral medications, his symptoms have shown minimal improvement.

Patient Overview:
Full Name: Harold Brownfax
Date of Birth: 01/25/1959

Relevant Medical History: No significant past medical history except for controlled hypertension. No previous surgeries. Non-smoker.
Current Medications: Amlodipine 5mg daily, ibuprofen as needed.
Symptom Details: The pain is primarily localized in the lower lumbar region, with occasional radiation to the right leg. Aggravated by prolonged sitting and physical activity.
Physical Examination Findings: Limited lumbar flexion due to pain, no obvious deformities, negative straight leg raise test.
Given the persistence and nature of Mr. Brownfax's symptoms, I am concerned about underlying conditions such as disc herniation or spinal stenosis that may require further evaluation and specialized care.

I would greatly appreciate your expertise in assessing Mr. Brownfax's condition and providing recommendations for further management. Attached are his most recent laboratory results and imaging studies for your review.

Please do not hesitate to contact me if you need additional information or have any specific recommendations regarding his ongoing care.

Sincerely,

Signed Electronically by,
Ejaz Anam MD
01/02/2023

(1) Automatic categorization of document type

Document Type
Correspondence

(2) Automatic extraction of physician name

Physician Name

Select Patient
Harold Brownfax (DOB: 1959-01-25, MRN: 40031660, Mo...)

SEARCH EPIC

(4) automatic search and retrieval of patient record from EPIC

(3) Automatic extraction of patient name & DOB from fax

USERS COMMENTS
SAVE COMMIT DELETE
CANCEL

3.6 x
Faster Processing Time

60,000 Hours
Annual Savings

This is not hype.

**Today is the James Watt
moment...**

for the human mind.

Engines liberated the body

From Houston to New York

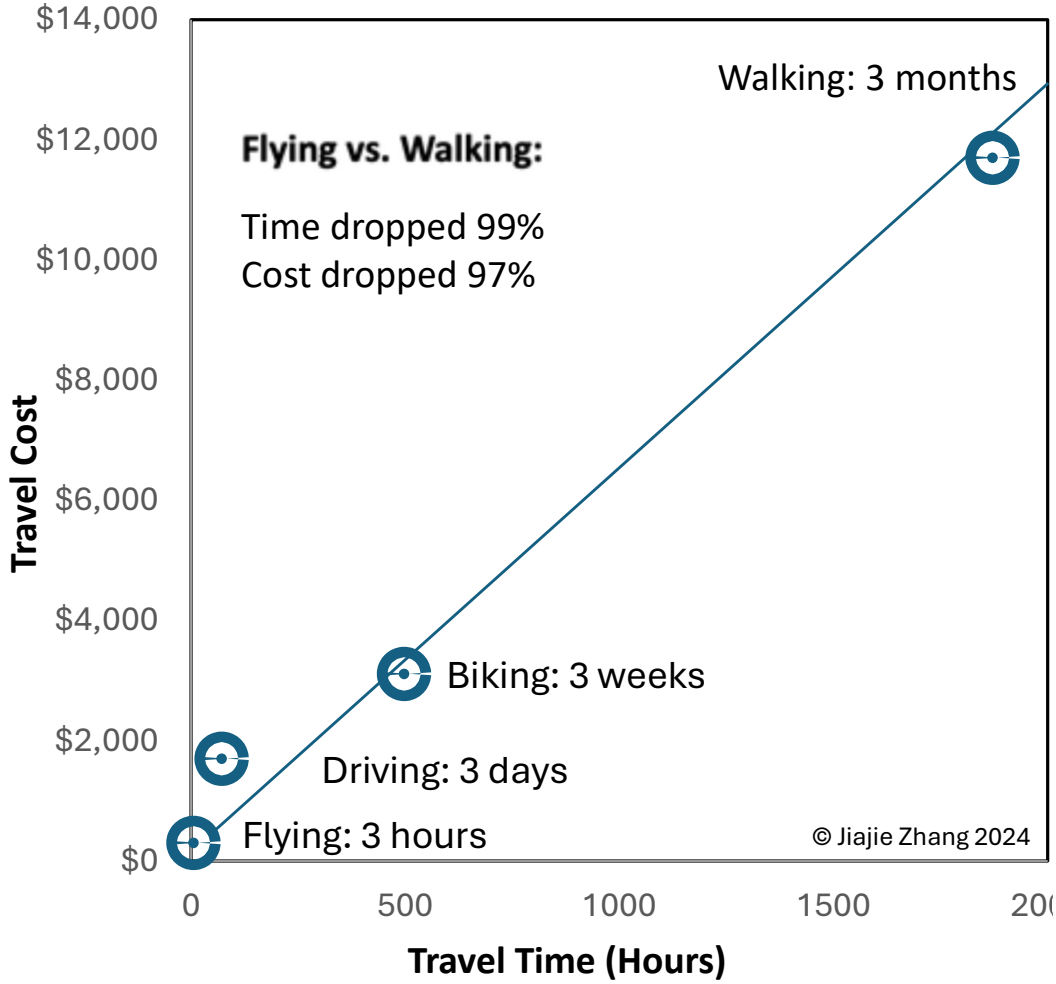

AI is now liberating the mind

Scan of AI Courses across 156 AMCs

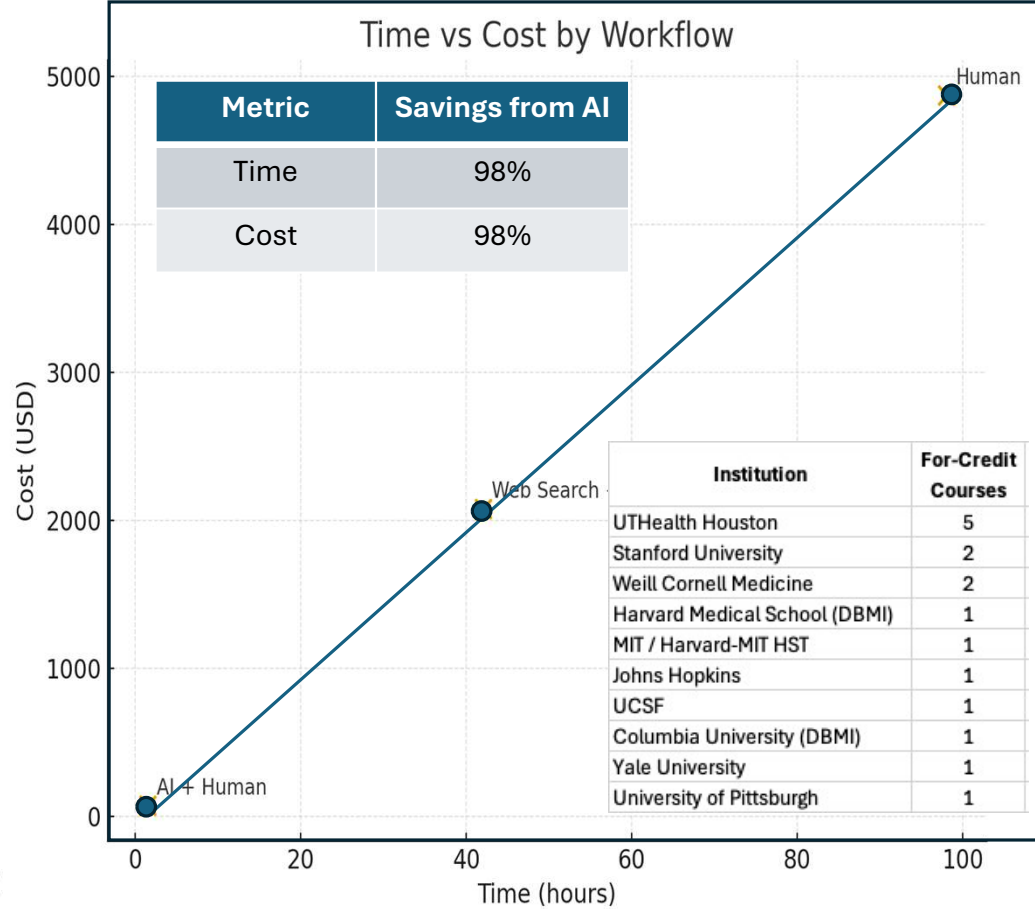

SOLVING THE PROBLEM OF MIND

1. Agriculture



Solved the problem of **Food**.
Enabled biological survival
at scale.

2. Industry

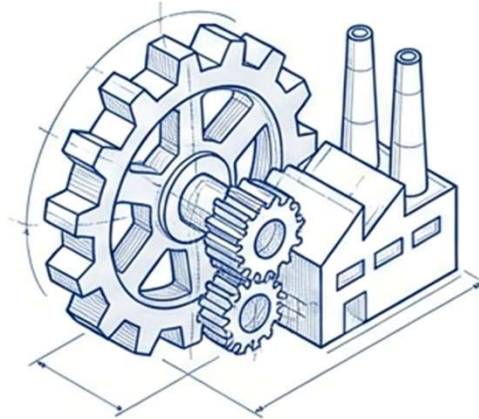

Solved the problem of **Muscle**.
Amplified physical labor
and productivity.

3. Artificial Intelligence

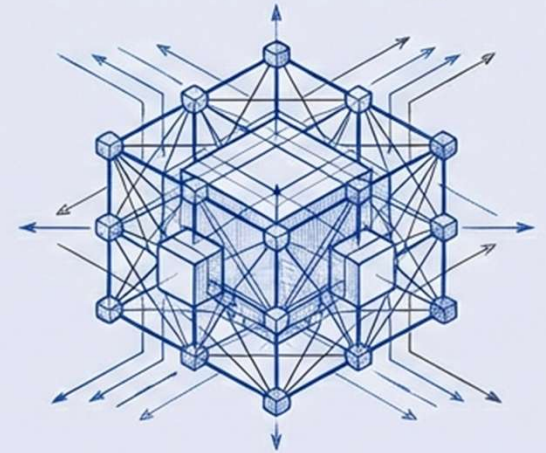

Solving the problem of **Mind**.
Addressing cognitive labor:
analysis, diagnosis, synthesis.

“This shift is not incremental. It is structural.”

Distributed Cognition – Human Technology System

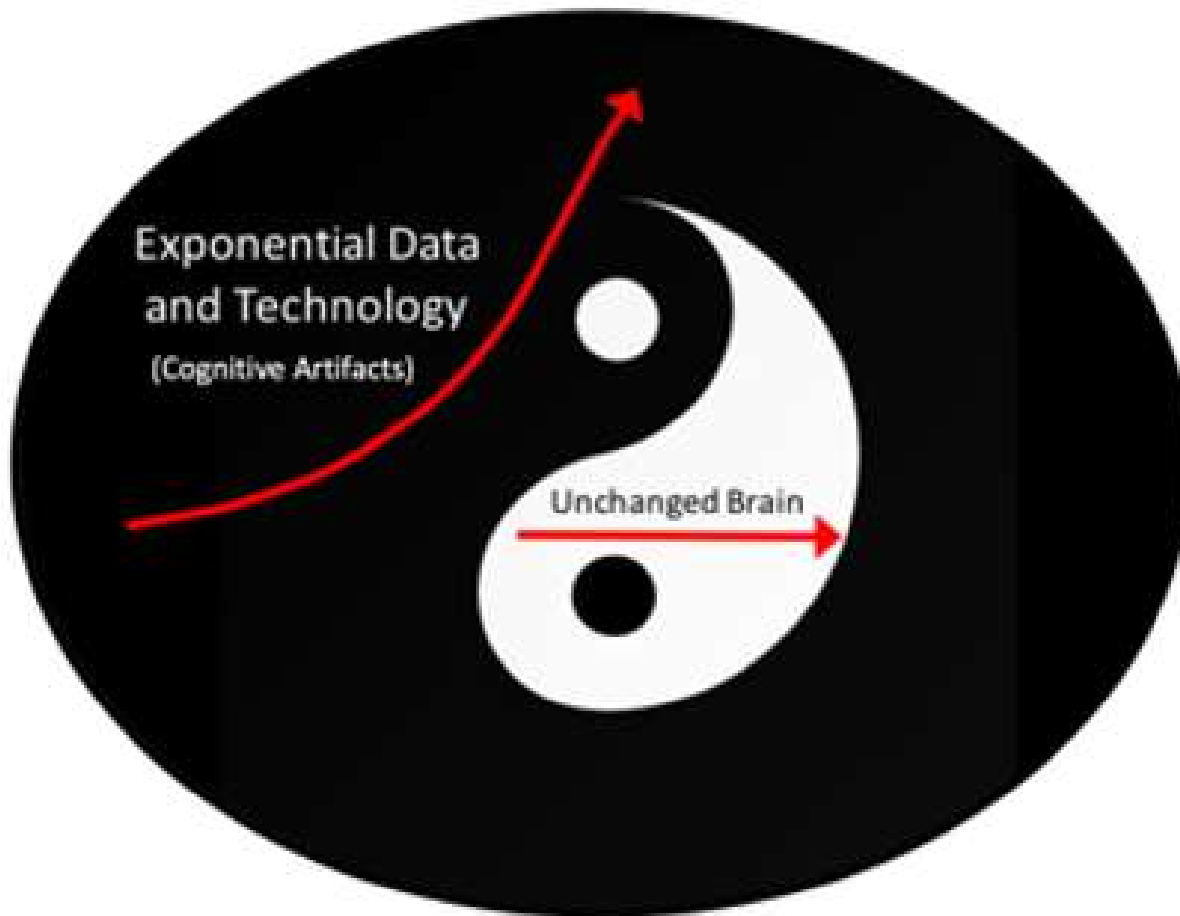

Distributed Cognition: AI and humans form a unified cognitive system—collaboration, not substitution.



Unified Knowledge: AI dissolves disciplinary silos, enabling holistic problem-solving.



Different Task: AI is not merely increasing cognitive efficiency—it is reshaping how cognitive work is structured and executed.

Zhnag, J. & Fenton, S. H. (2024) Preparing healthcare education for an AI-augmented future. npj Health Systems. <https://doi.org/10.1038/s44401-024-00006-z>

Zhang, J., & Norman, D. A. (1994). [Representations in distributed cognitive tasks](#). Cognitive Science, 87-122.

Chest Pain Diagnosis

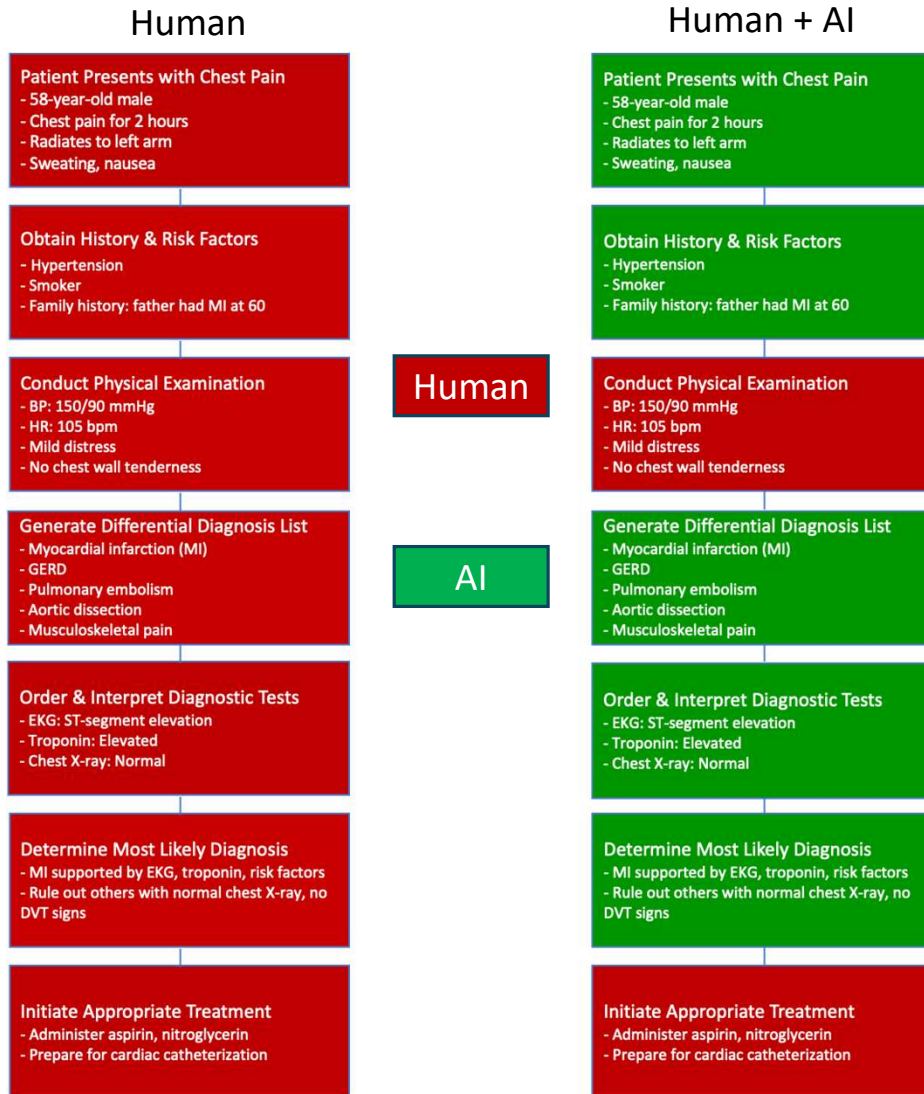

Cognitive Work Is Restructured

- data entry → data verification
- memory recall → recognition
- generating hypotheses → evaluating hypotheses
- rule-based decision making → context-sensitive judgment

The AI-Native Institution

From Initiative to Infrastructure

A Strategic Framework for Institutional Redesign

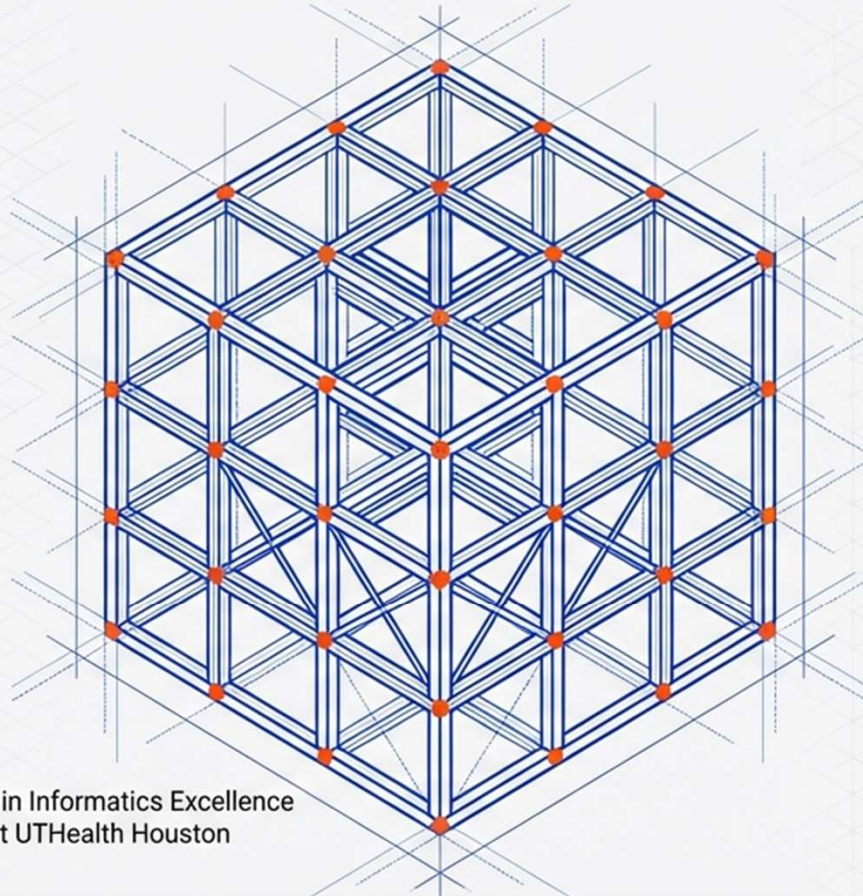

Jiajie Zhang, PhD, Dean
Glassell Family Foundation Distinguished Chair in Informatics Excellence
McWilliams School of Biomedical Informatics at UTHealth Houston

Industrial Time vs. Cognitive Time

Industrial Architecture

Designed for Stability

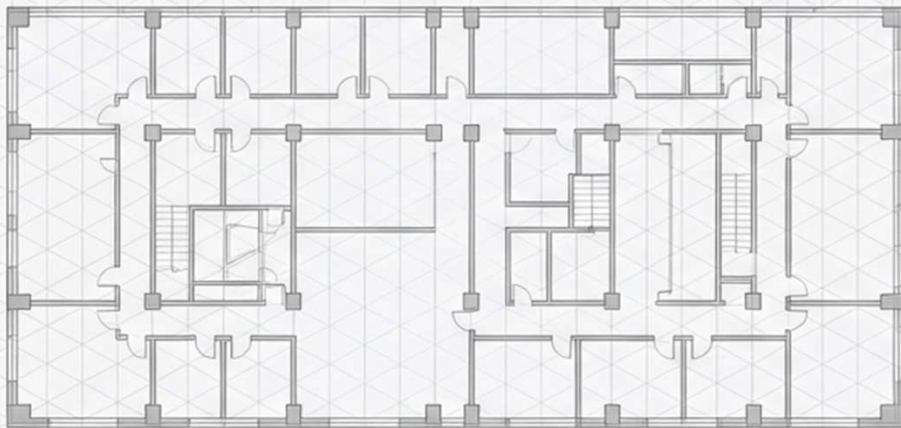

- Annual budget cycles
- Five-year strategic plans
- Periodic accreditation
- Linear research pipelines

Cognitive Reality

Designed for Velocity

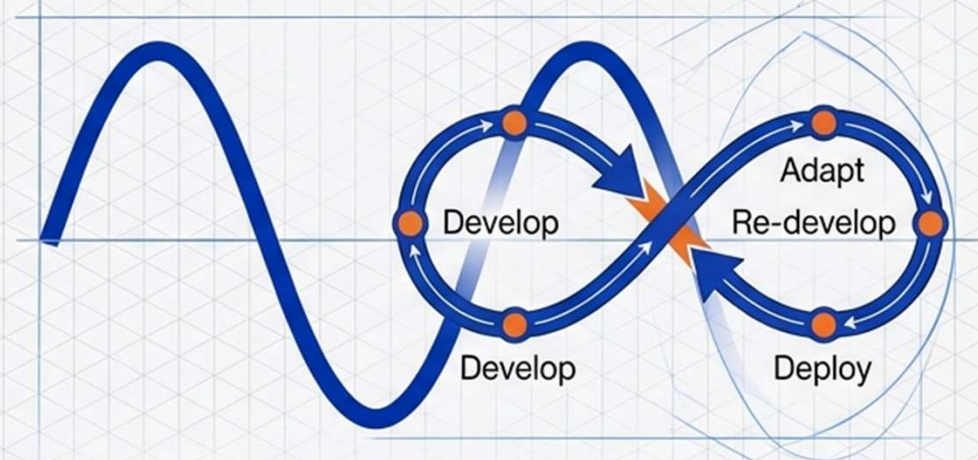

- Models improve continuously
- Data refreshes continuously
- Clinical signals update in real time
- Performance measured continuously

The problem is not technological capability. It is institutional velocity.

Innovation Theatre

The Risk of Surface Adoption

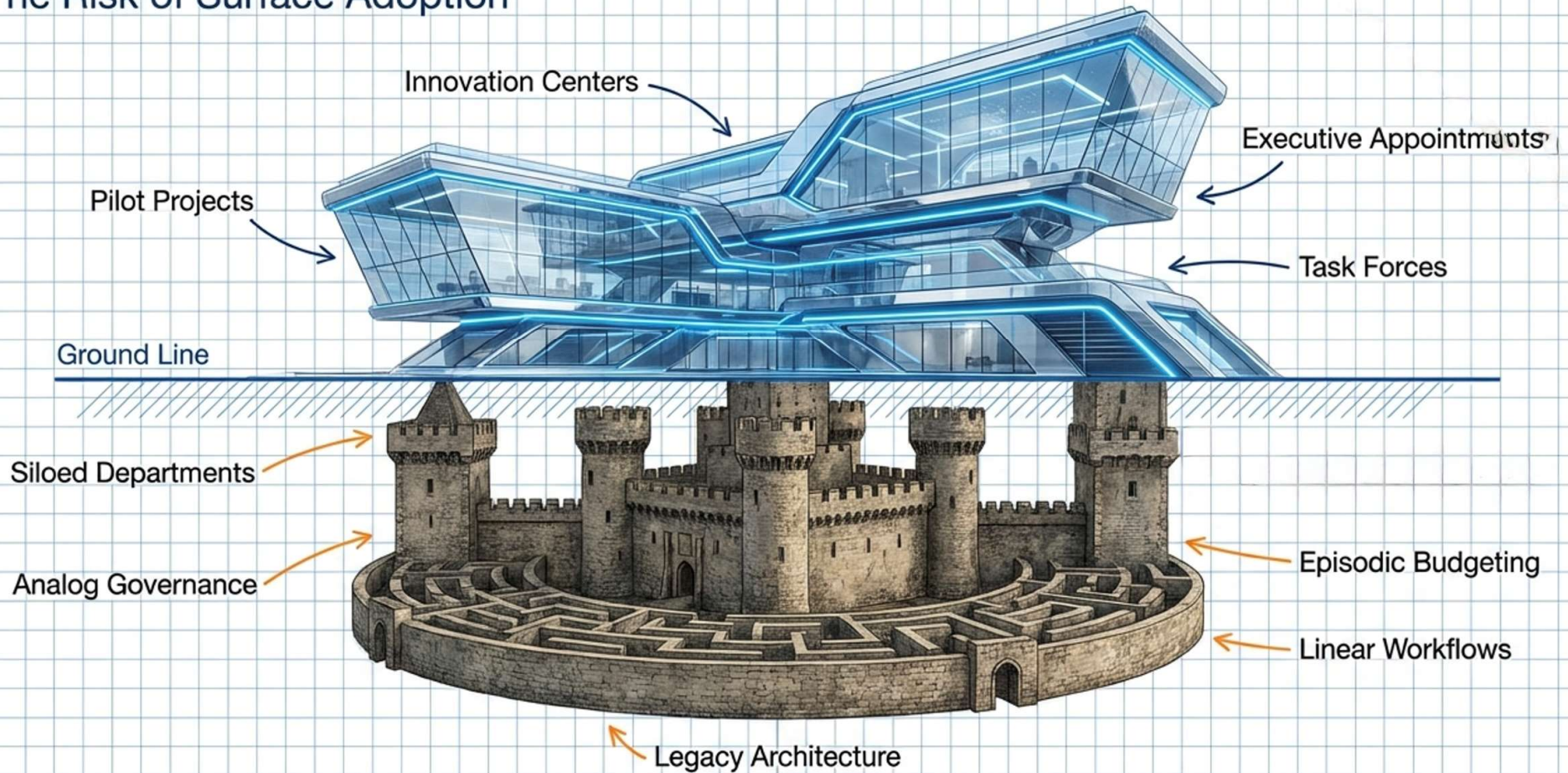

An Executive Challenge, Not a Technical One

The Misconception

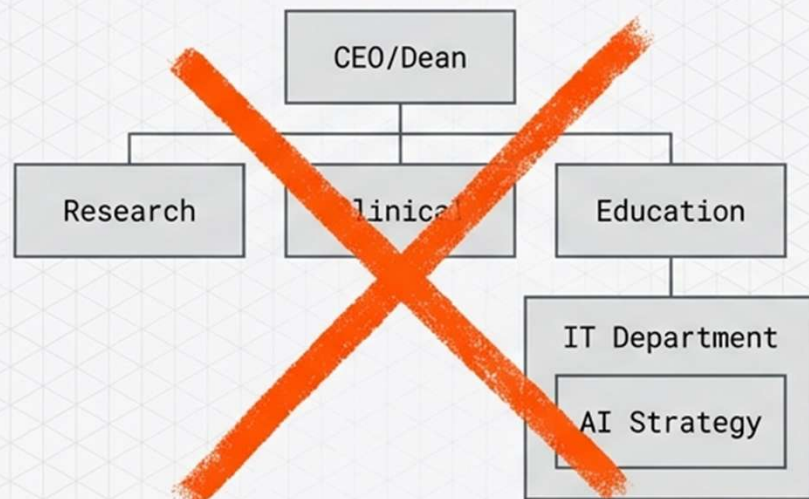

Delegated to IT

The Imperative

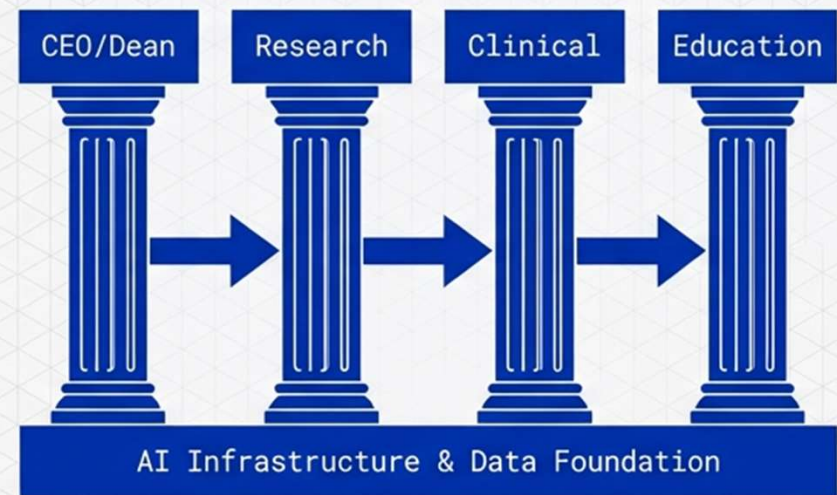

Executive Led

The "Industrial" leader delegates AI to IT.
The "AI-Native" leader treats AI as strategy.

Redesigning for Scalable Cognition

An AI-native institution does not merely adopt tools.
It reorganizes cognitive labor deliberately.

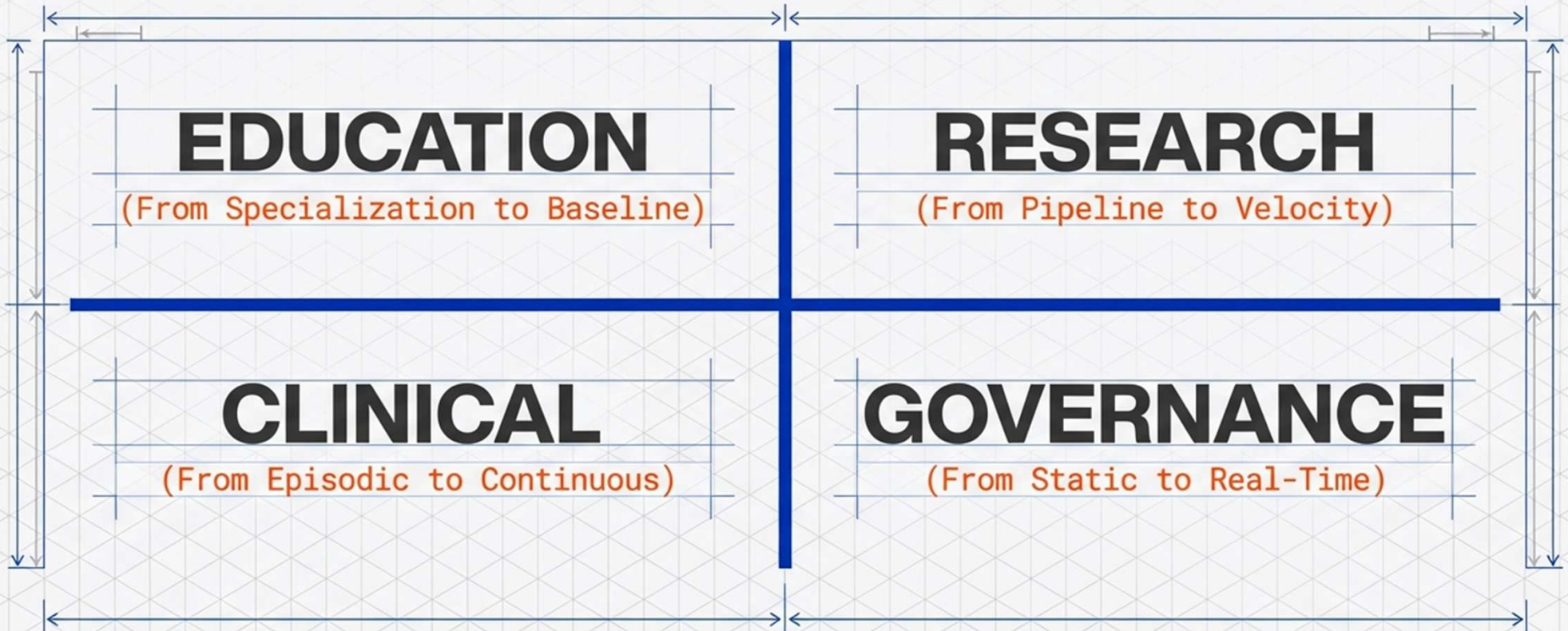

Pillar 1: Education

From Specialization to Baseline Competence

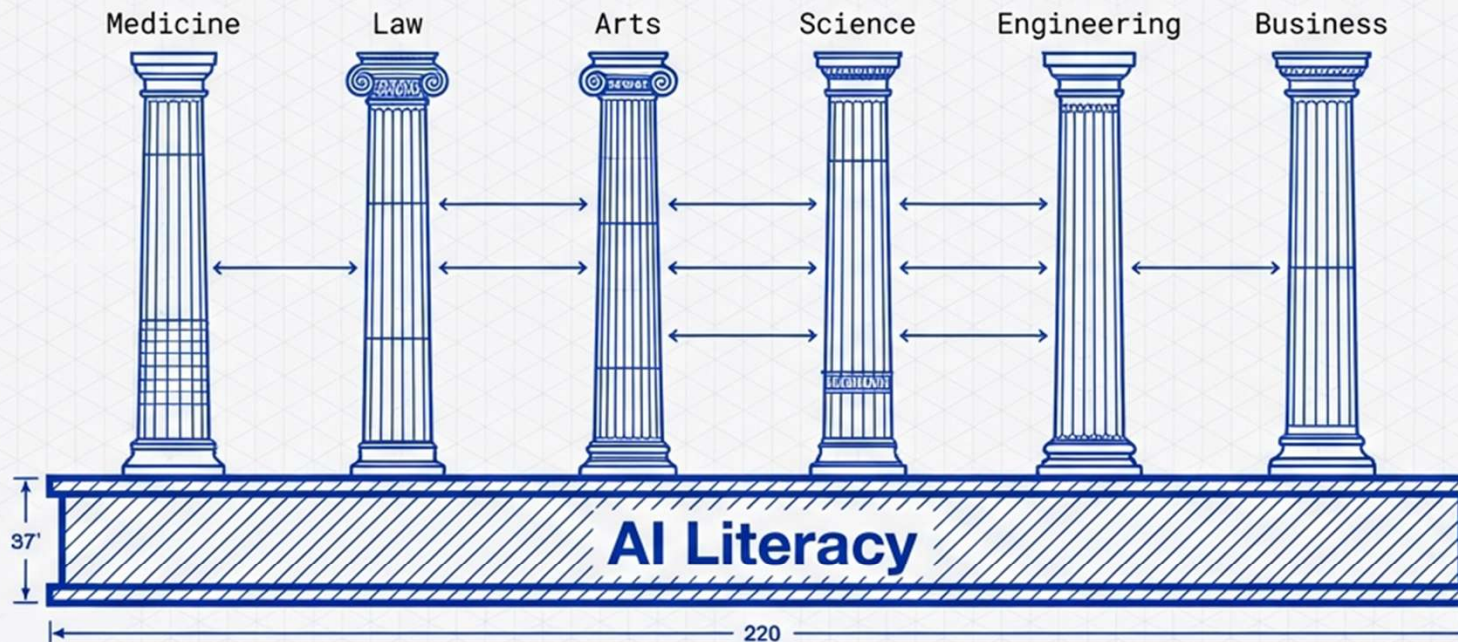

The Shift:
FROM AI as a specialized degree →
TO AI literacy as a foundational requirement.

The Requirements:
Graduates must understand how to collaborate with machine intelligence and apply AI responsibly.

“This is not specialization. It is baseline competence.”

Pillar 2: Research

Accelerating Discovery Velocity

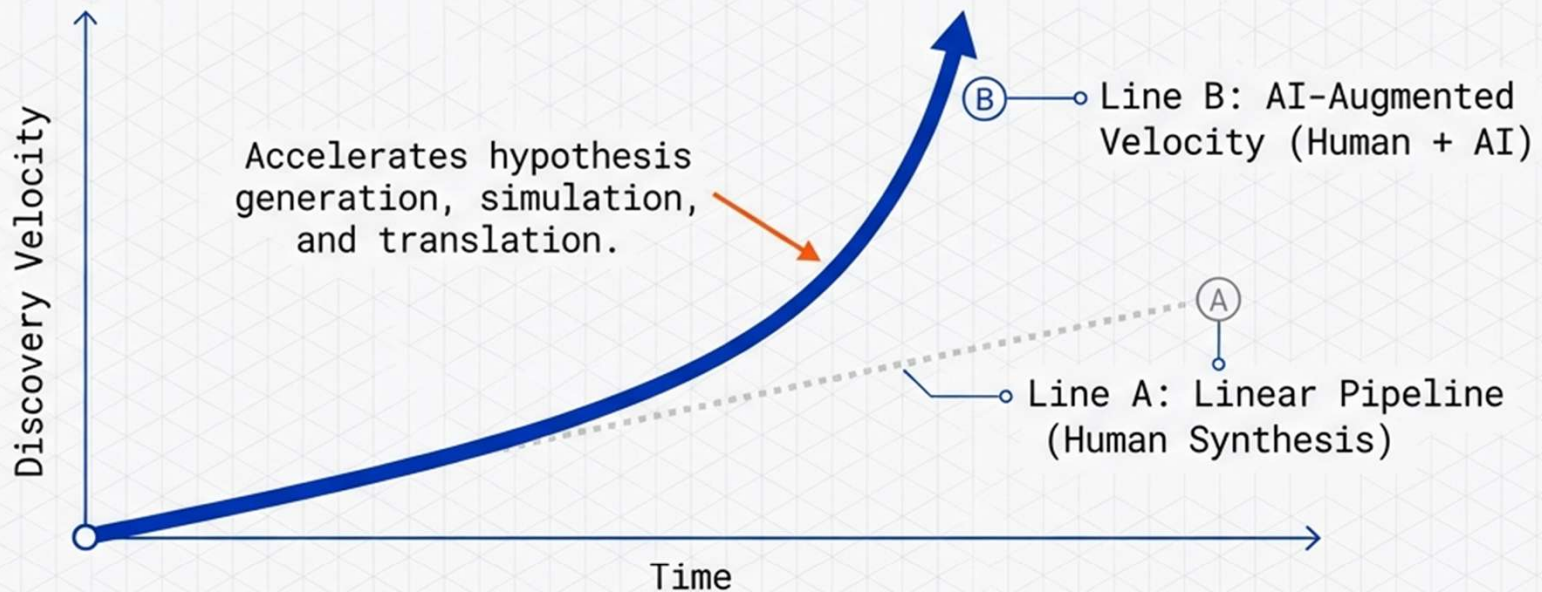

Institutions that integrate AI into research architecture **increase discovery velocity and funding competitiveness.**

Pillar 3: Clinical Systems

From Episodic Care to Continuous Learning

Fragmented & Reactive Episodic Care

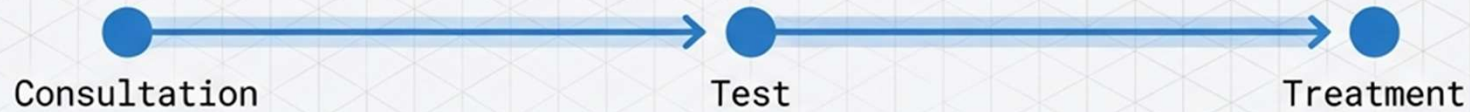

Integrated & Proactive Continuous System

Warning: Critical Condition

Without redesign, AI amplifies fragmentation.
With redesign, AI amplifies intelligence.

Pillar 4: Governance

The Decisive Layer

If AI remains outside governance, institutional intelligence does not scale.

Governance must evolve from static oversight to real-time adaptability.

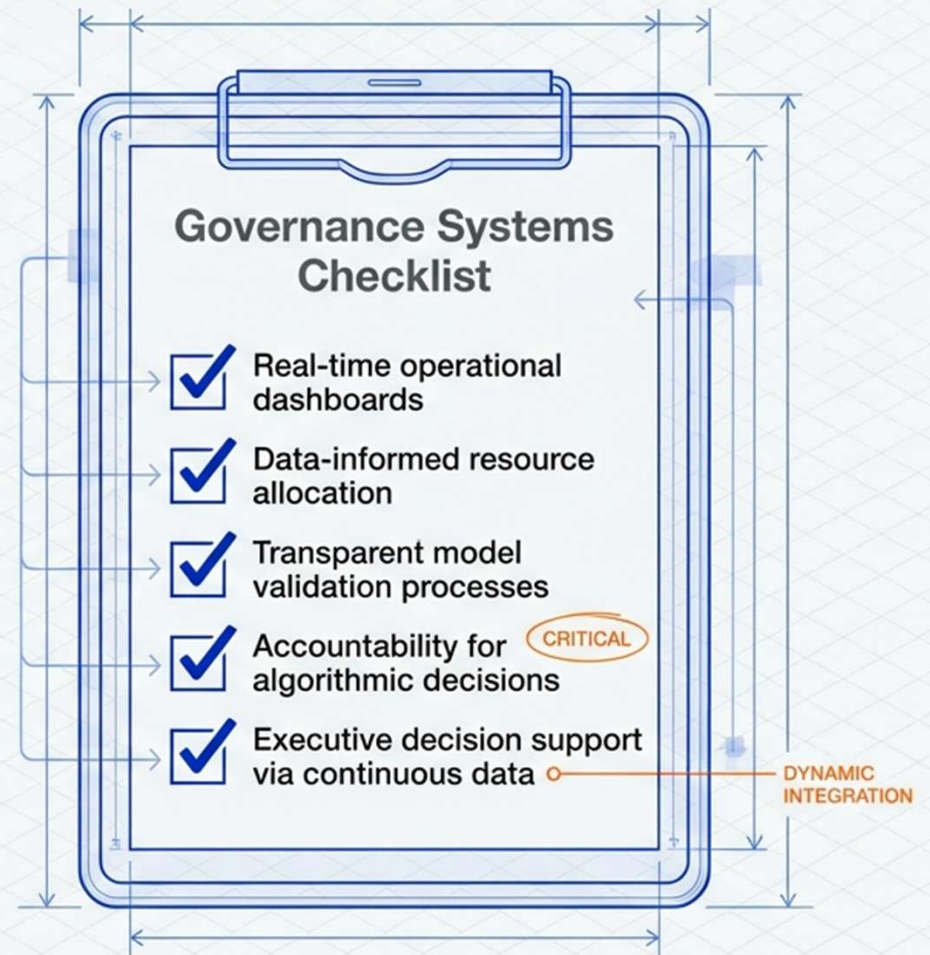

The Cost of Delay

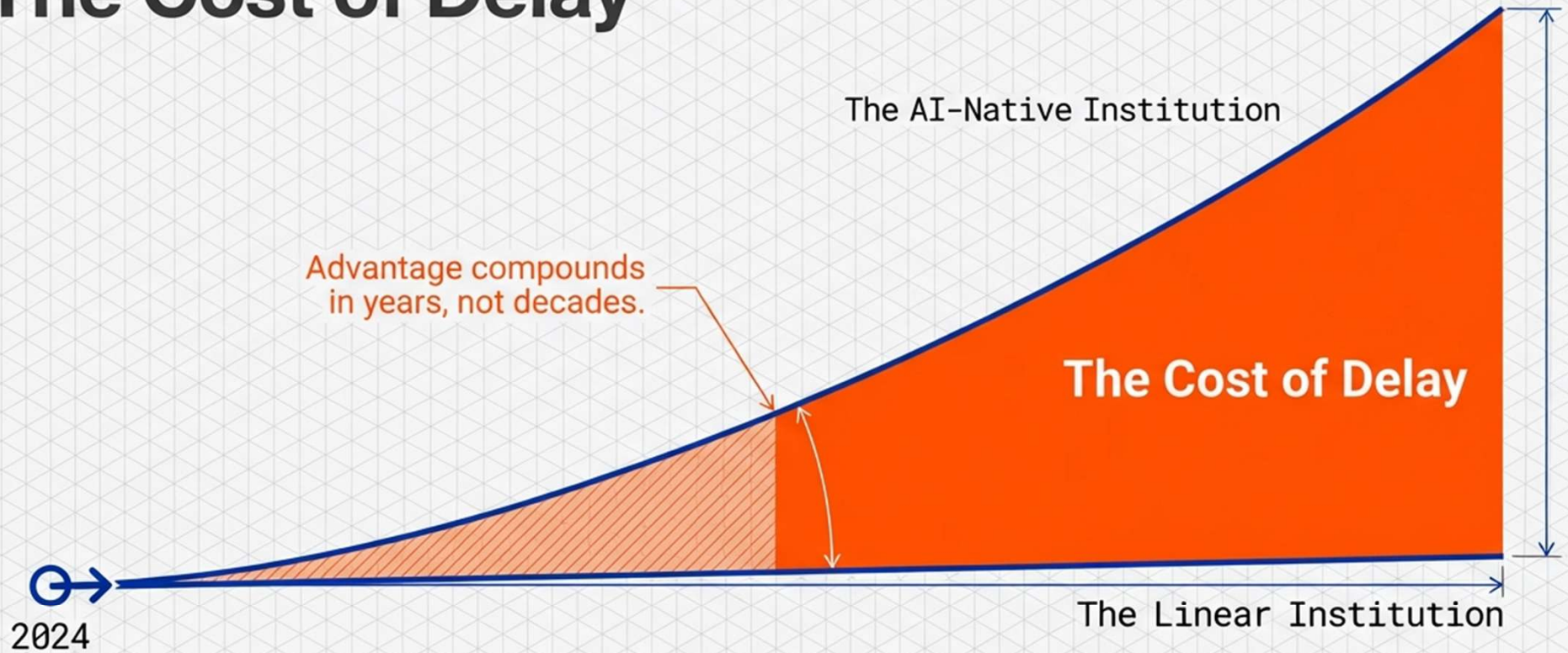

The question is not whether to adopt AI. It is whether to redesign yourself around it.



McWilliams School of Biomedical Informatics

<https://sbmi.uth.edu>



jiajie.zhang@uth.tmc.edu



[jiajie.zhang.92](https://www.facebook.com/jiajie.zhang.92)



[JiajieZhang100](https://twitter.com/JiajieZhang100)



[jiajieZhang](https://www.linkedin.com/in/jiajieZhang)

TRANSFORMING DATA TO POWER HUMAN HEALTH™