A photograph of a suspension bridge over a river, with a dark semi-transparent overlay in the center containing white text. The bridge has a metal railing and cables. The background shows a lush green forest and a blue sky with some clouds.

TEMPLE UNIVERSITY
ENGINEERS
WITHOUT BORDERS,
NUEVA JERUSALEN
PROJECT

**TEMPLE UNIVERSITY
ENGINEERS WITHOUT BORDERS MISSION**

We aim to build a better world through engineering projects that empower communities to meet their basic human needs.



Our Chapter's Approach



CANVA STORIES

0917

01 Local Outreach

Work with community gardens and local nonprofits in the Greater Philadelphia region to help **enhance the support they provide to the local community.**



CANVA STORIES

0917

02 International Collaboration

Collaborate with international communities to develop optimal solutions to their most pressing issues.



0917

03 Empower Next Generation of Engineers

Cultivate a fun and inclusive community where students can gain hands on experience and work with professional engineers to solve real world problems.



Nueva Jerusalem Community

**Indigenous Kichwan community of 300,
located in Napo, Ecuador**

- Lack access to reliable sanitation facilities
- Mostly subsistence farmers
- Health concerns amongst infants and seniors
- Severe coliform and heavy metal contamination



Nueva Jerusalem Sanitation Project

OBJECTIVE

Reduce water contamination and improve the community's public health by constructing reliable latrines and handwash stations.

Current Access to Sanitation Facilities

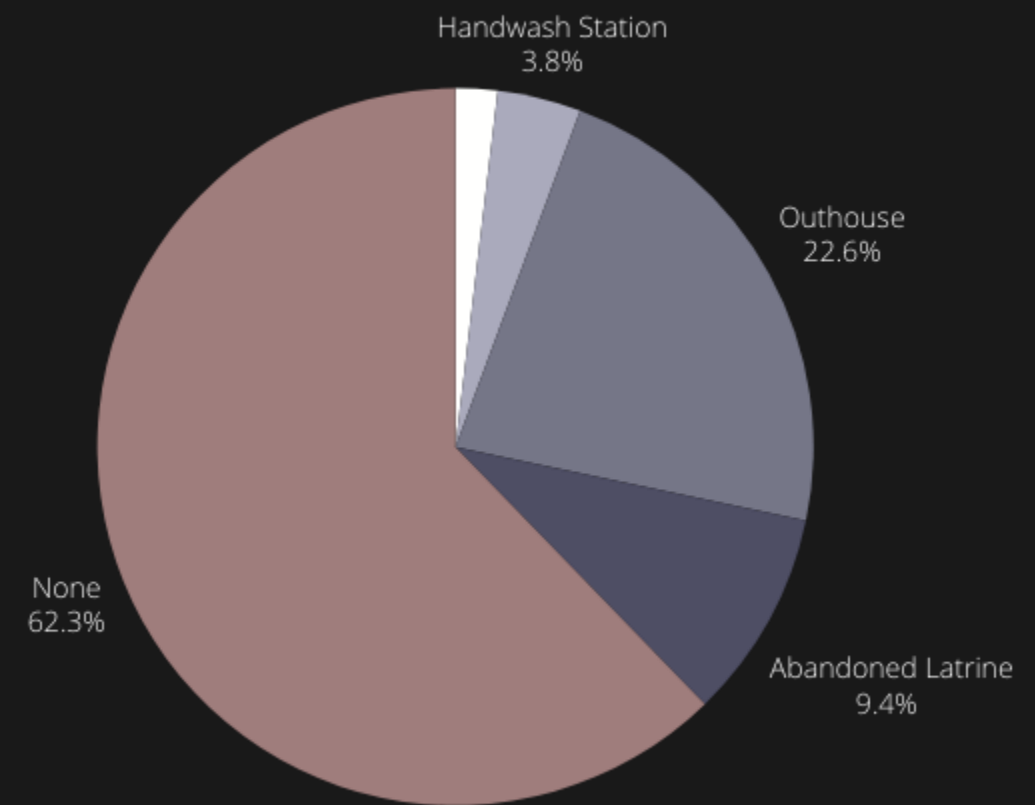

Sanitation Project Timeline



Assessment

(05.25.23 - 05.31.23)

Built relationships with community members and local NGO, surveyed the households, and tested water and soil samples

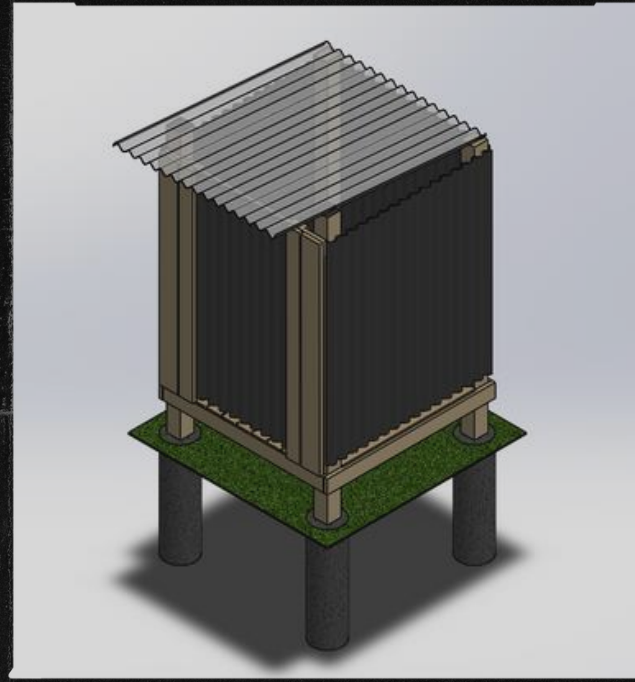

Pilot Implementation

(05.23.24 - 06.03.24)

Will construct 8 pilot prototypes, to then monitor the community response and system effectiveness



Full Implementation

(05.25 - 06.25)

After improvements to the pilot system design, will install concrete latrine systems in all 52 households



Monitoring

(05.26 - 06.26)

Performing repairs and maintenance while collecting data for environmental analysis and system evaluation

Water Quality Within the Community

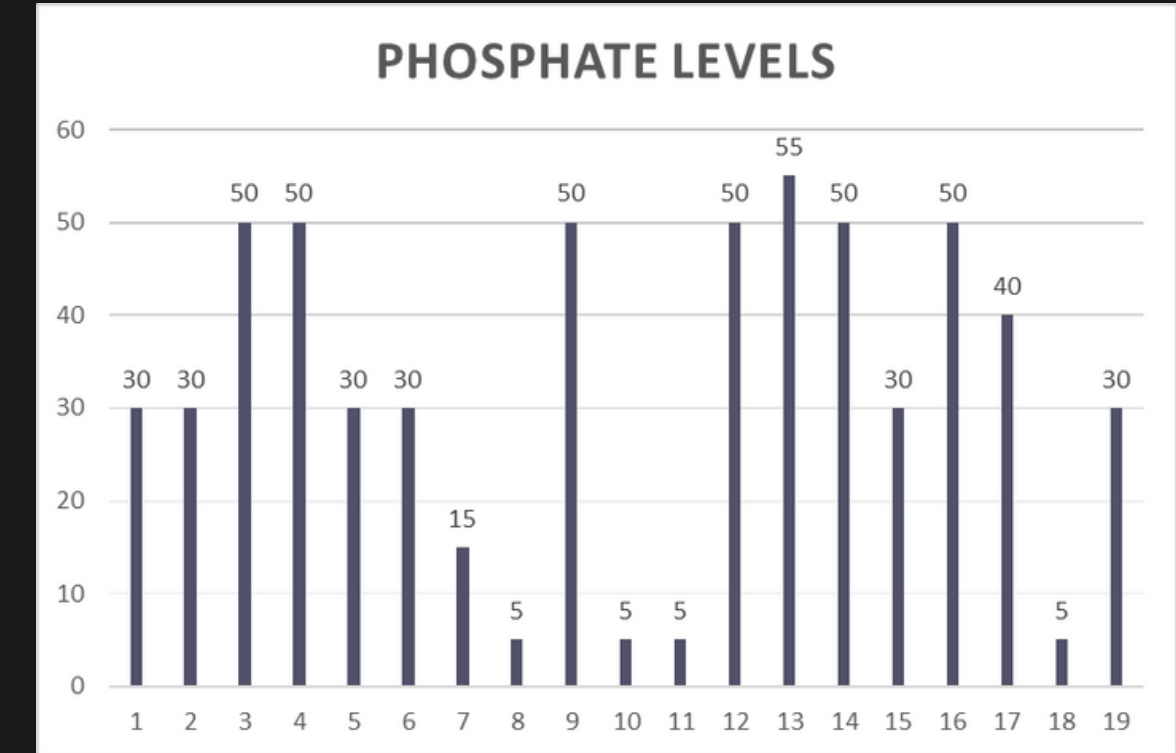
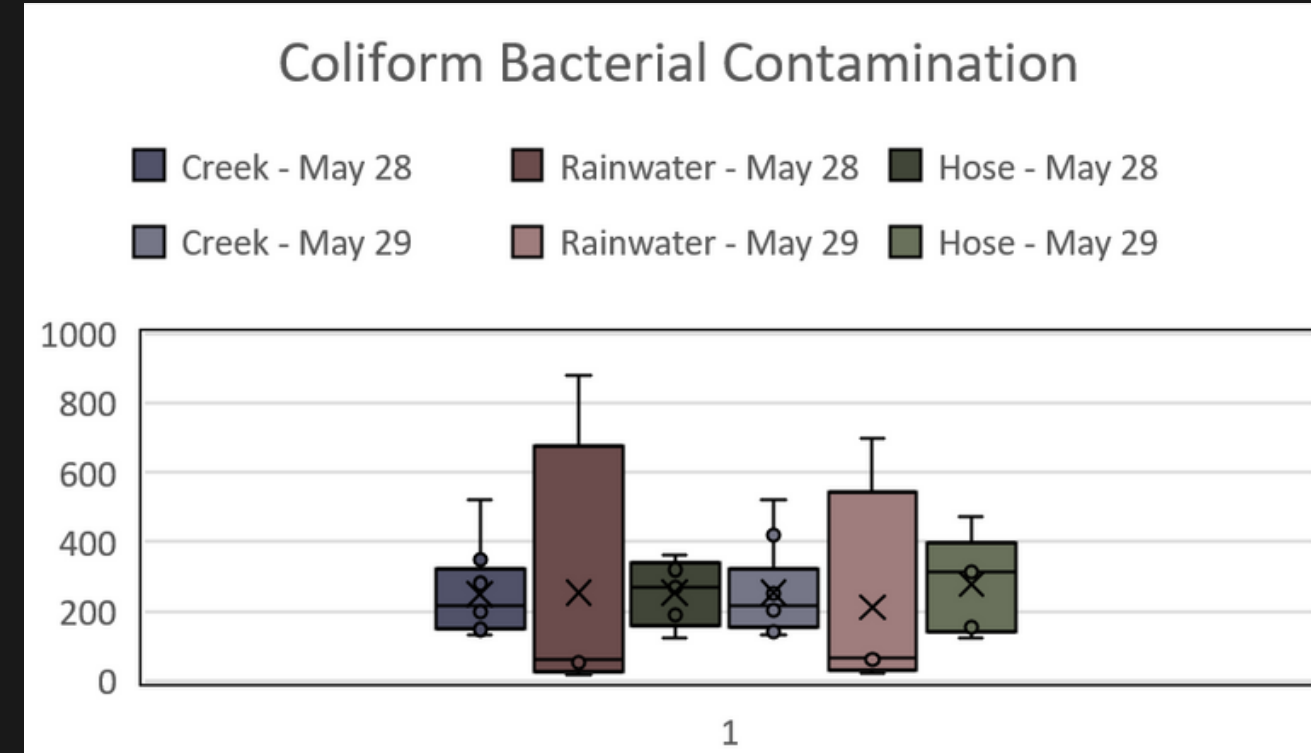
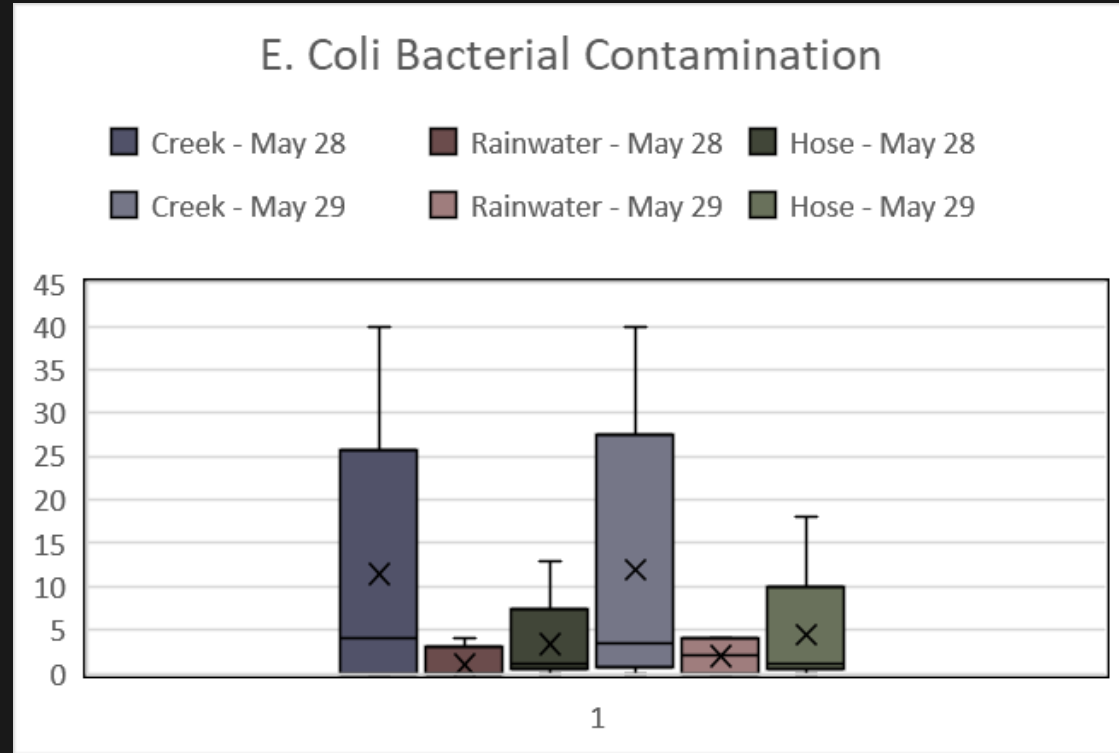

PRIMARY WATER SOURCE

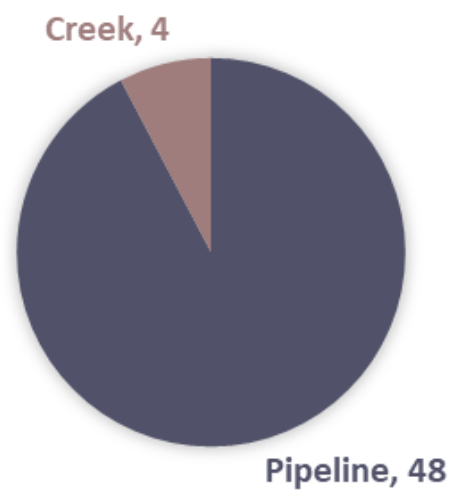

USE OF FILTERED WATER

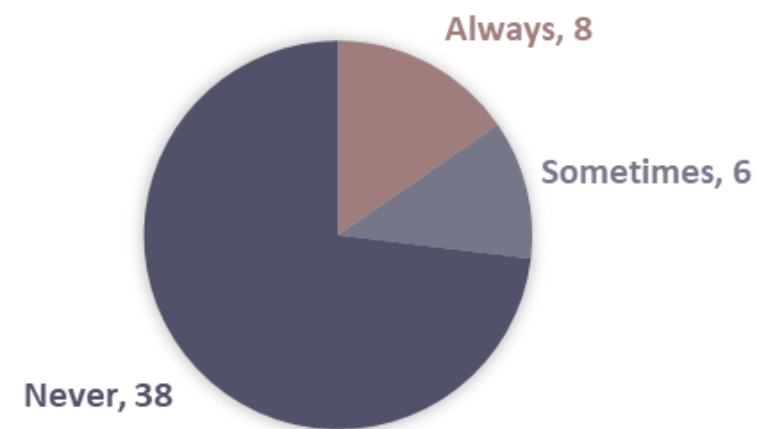

Severe bacterial contamination in creek and pipeline water sources, in addition to high phosphate levels. Majority of the community consumes pipeline water and a few consume water from the creek.

Lessons Learned

Data Collection

- Demographic data can be challenging to collect and the community did not have any historical data

Operations and Management Training

- Community members do not currently have the technical knowledge to operate the proposed latrine systems

Communication

- Being a Spanish-speaking community, we require translators to communicate with the community efficiently



Pilot Implementation Systems

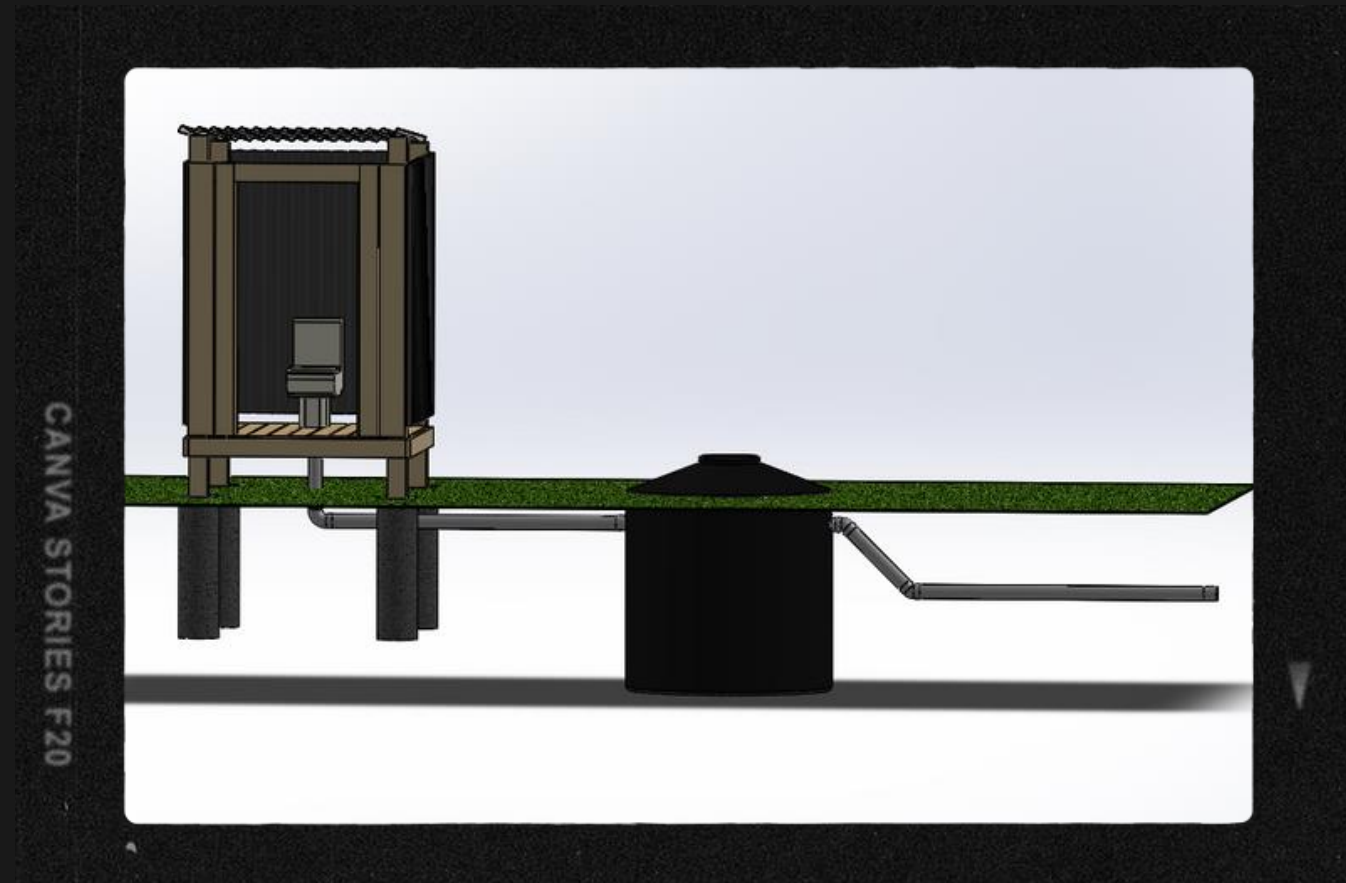

Biodigester Latrine

- Operates on the user-end as a simple latrine
 - Plumbing connects a toilet bowl to a waste-collection tank
- The waste-collection tank contains limestone
 - works to break down the waste
 - introduces and sustains waste-consuming microbes
- Waste should be pumped out once every 3-5 years



Compost Latrine

- Waste is collected and added to a separate compost pile
- User must throw a small amount of damp organic cover material over the excrement
- Takes 12 months to fully compost the waste, after which the compost can be used as fertilizer

Cost of Pilot Implementation

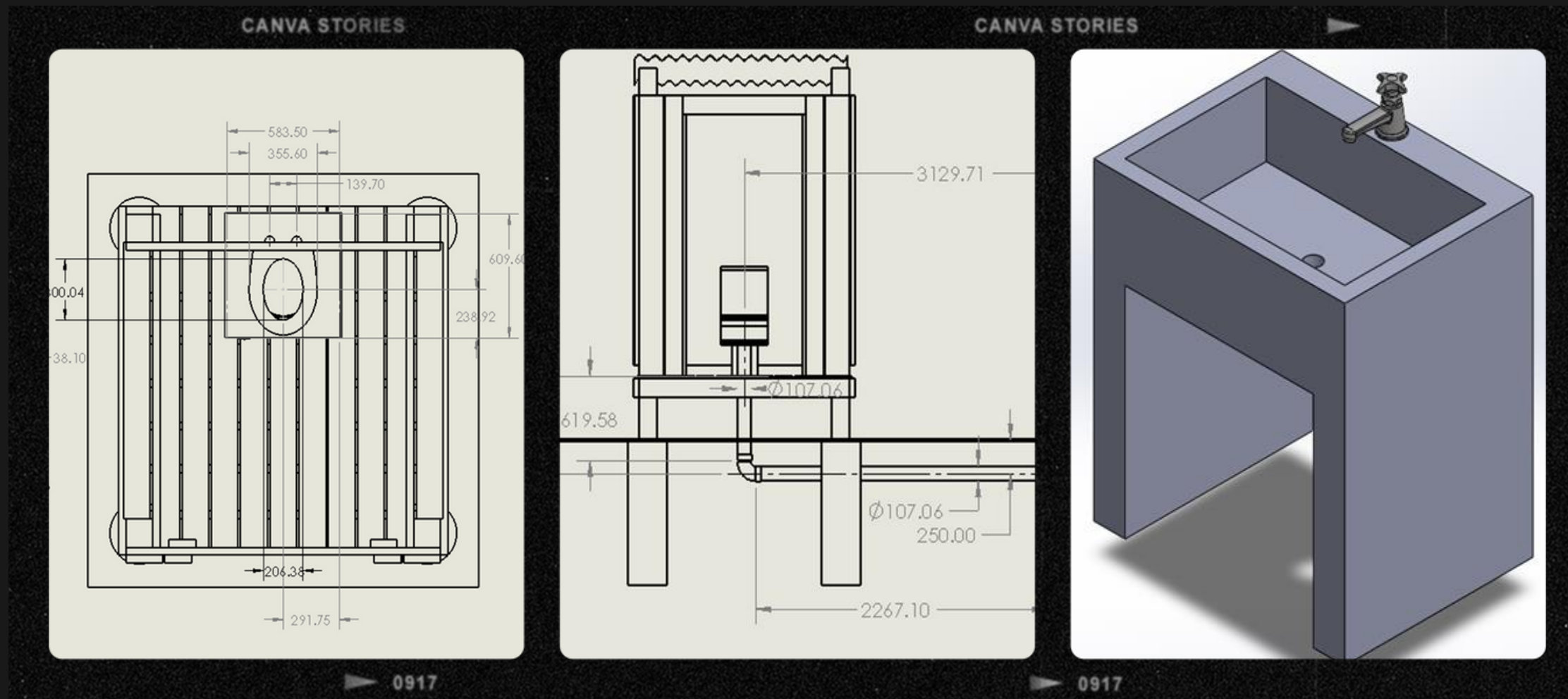

Compost Latrine

\$784

Biodigester Latrine

\$ 1,082

Handwash Station

\$98

	Quantity	Total
Compost	4	\$ 3,136
Biodigester	4	\$ 4,328
Sink	8	\$ 784
	TOTAL	\$ 8,248



CANVA STORIES 200



003
CNVFILM 200

Thank you all for your time!



18
CNVFILM 200



CANVA STORIES 200

Contact Us

templeuniversity@chapters-ewb-usa.org

<https://sites.temple.edu/ewbtemple/>

Instagram: temple_ewb

LinkedIn: Temple University Engineers Without Borders