



FALLBROOK DESIGN GUIDELINES

Fallbrook Planning Area
County of San Diego

FALLBROOK DESIGN GUIDELINES

BOARD OF SUPERVISORS

Brian P. Bilbray
First District

George F. Bailey
Second District

Susan Golding
Third District

Leon L. Williams
Fourth District

John MacDonald
Fifth District



Department of Planning
& Land Use

Prepared pursuant to Sections 5760 and 5799b
of the San Diego County Zoning Ordinance
by the Department of Planning and Land Use.

Reviewed by the Planning Commission
on March 3, 1989

Approved by the Board of Supervisors
on April 3, 1989

Fallbrook Design Guidelines

TABLE OF CONTENTS

Part 1. The Design Review Process	1
Part 2. Community Design Objectives.....	5
Part 3. The Design Guidelines	7
A. General Guidelines Applicable To All Development Projects.....	9
A1. Site Design Process.....	11
A2. Preservation Of Significant Trees	14
A3. Old And New Design Relationships.....	17
A4. Architectural Character	19
A5. Landscape Character.....	24
A6. Design For Climate And Energy Conservation.....	26
A7. Signage.....	27
A8. Site Lighting.....	31
A9. Building Equipment And Services.....	32
A10. Preservation Of Historic Buildings.....	33
B. Guidelines By Development Type And Area	35
B1. Commercial Development In The Town Center.....	37
B1-A. Commercial Development In The Town Center: Main Street And Mission Road.....	38
B1-B. Commercial Development In The Town Center: Side Streets.....	43
B2. Commercial Development Outside The Town Center	45
B3. Multi-Family Residential Development.....	48
B4. Industrial Development.....	54
C. Guidelines For Areas With Special Environmental Considerations.....	57
C1. Scenic Roads.....	59
C2. Hillside Development.....	61
C3. Development In Flood Plains	65
Part 4. Design Review Application Requirements.....	69
Appendix A. Plant Selection Guide.....	73

ACKNOWLEDGEMENT

The first families coming to Fallbrook many years ago liked this pleasant setting among the big trees and hills. Much of the beauty remains for our enjoyment and protection. The interest in Design Review as a means of preservation and improvement may have commenced with Roy Noon in 1968, then president of the Fallbrook Chamber of Commerce, with his efforts to save the old railway depot and have a Main Street out of our past. In 1983 David Lowry was elected to the Fallbrook Community Planning Group, later becoming its chairman, succeeding Gib Moudry, and from the outset Lowry encouraged efforts to protect and improve our community, forming a Committee to commence development of design review guidelines. A smaller interim committee continued, receiving project funding in late 1987. Members of the committee for preparation of the Design Guidelines were Trudi Boylan, Edward Ferraro, Ralph Lash, Jeff Lyon, AIA, Mary Jane Pfeil, and Chairman Jim Porter.

Prepared by:

Gerald Gast, AIA, Urban Design and Architecture

Gerald Gast, AIA; James B. Guthrie, AIA
with
Kathryn Fulhorst, ASLA, Landscape Architect

San Diego County Department of Planning and Land Use

PART 1. THE DESIGN REVIEW PROCESS

This booklet outlines the Design Guidelines for development in the Fallbrook Community Planning Area.

Design Review in Fallbrook is administered by the San Diego County Department of Planning and Land Use as part of the development review process. Projects are evaluated by the Fallbrook Design Review Board, a panel of citizens appointed by the County Board of Supervisors. Actions of the Design Review Board are advisory to the various County authorities (Director of the Department of Planning and Land Use, Planning and Environmental Review Board, Zoning Administrator, Planning Commission and Board of Supervisors) who issue decisions on development proposals.

The Fallbrook Design Review program is intended to allow the Fallbrook Design Review Board an opportunity to influence the physical design aspects of development projects in Fallbrook. In this capacity, the Design Review Board is the lead citizen group in matters involving the design of the types of projects specified in this manual. The Fallbrook Planning Group, however, continues to be the lead group in matters involving land use (i.e. use permits, subdivision review, specific plans, rezones). Where land use proposals also involve the physical design subjects covered by these guidelines, it is intended that the Planning Group will work closely with the Design Review Board to encourage the consistency of proposals with the Fallbrook Design Guidelines.

DEVELOPMENT SUBJECT TO DESIGN REVIEW

Design Review is a required step in the development approval process for the following types of projects located within the boundaries of the Fallbrook Community Planning Area:

- All commercial development
- All industrial development
- All multi-family residential development on land zoned at a density of 7.3 dwelling units per acre and over. A "multi-family residential development" is defined as a project containing three or more attached dwelling units.
- The following Major Use Permits where they also require the issuance of building permits for construction or alteration of buildings: planned developments; mobile home parks; churches; administrative services; clinics; community recreation facilities; cultural exhibit and library buildings; group and child care centers; lodge, fraternal and civic assembly buildings; emergency or utility service facilities. It is intended that the Community Planning Group will work with the Design Review Board and the applicant to encourage consistency of Major Use Permits with applicable design guidelines.

THE PURPOSE OF DESIGN REVIEW

Design Review is one of several review procedures used by the County to protect the public welfare and environment. The process is a comprehensive evaluation of those characteristics of a development which have an impact on neighboring properties and the community as a whole. Design Review makes a careful examination of a project's quality of site planning, architecture, landscape design and important details such as signage and lighting. The purpose is to insure that every new development will carefully consider the community context in which it takes place and make a conscientious effort to develop a compatible relationship to the natural setting, neighboring properties and community design goals.

Fallbrook citizens have strong feelings about the quality of the community's natural setting, agricultural history, village-like Town Center and rural residential character. The Design Review process is intended to protect and retain Fallbrook's pleasant rural environment. Fallbrook's community landscape and built environment will affect the quality of life of present and future generations. Citizens expect approved developments to contribute to this quality.

Design Review is a process based on fair and reasonable standards. The Design Review Board is sensitive to both developer and community concerns. The Board will work with the community and developers to weigh all considerations, be flexible when necessary, and do its best to reach fair decisions when there is a difference of opinion.

HOW THE DESIGN REVIEW PROCESS WORKS

The Fallbrook Design Review Board evaluates development proposals using the Design Guidelines described in this manual as criteria. The Board may recommend to:

- Approve or disapprove proposals.
- Approve proposals subject to conditions.
- Request the applicant to re-submit the proposal with specific changes.

Decisions of the Design Review Board are advisory to the various approving authorities, that will issue final decisions on development approval. Appeals of decisions are handled through normal County planning appeals procedures.

Review Board members should be instructed by Department of Planning and Land Use staff on the application of the Guidelines, the limits of the Board's review, and the necessity for substantiating the Board's recommendation by identifying those applicable Guidelines that are satisfied or not satisfied by the development proposal.

STEPS IN THE REVIEW PROCESS

1. STAFF CONFERENCE

Before planning and design begins, the developer or his designer is urged to meet with the County Planning staff relative to Fallbrook Design Review. The nature of the project and site should be described. The Planning staff member will clarify review procedures and submittal requirements. Critical design issues and Design Guidelines important to the project may be discussed.

2. PRELIMINARY REVIEW (Optional)

This step is optional but recommended for large or complex projects and projects requiring extensive grading or alteration of natural features.

Preliminary Review allows the developer to meet with the Design Review Board to discuss basic intentions and plans before investing time in detailed design. At this stage, site design, location of buildings, grading, basic form of buildings and landscape concepts are important. Building elevations and other information may be discussed but should be kept in preliminary form.

Preliminary Review is an informal process enabling the applicant to receive input from the Design Review Board and get its opinion on the basic concept of the development proposal. The Board will not normally take official action or vote on a project until Final Application and Review.

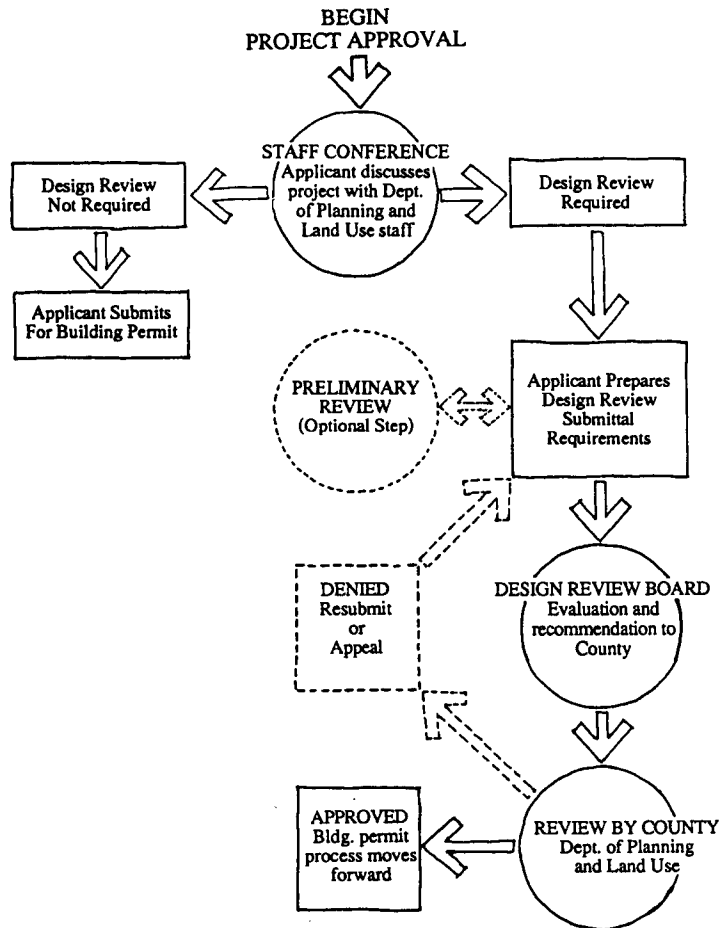

APPLICATION PROCESS

3. WAIVER CONSIDERATIONS

Occasionally, on minor projects, the Design Review Board may recommend a waiver of the final application and review requirements. Projects which may be considered for this waiver include:

- a. Projects which are minor in nature and preliminary review satisfies the Design Review Board's concern.
- b. Projects which if subjected to final application and review requirements would not materially contribute to the attainment of the community design objectives.

4. FINAL APPLICATION AND REVIEW

The one required step in the Design Review process, unless a waiver has been granted, is submittal of a Final Application and appearance before the Design Review Board. Submittal requirements for Final Application and Review are given in Part 4 of this booklet.

Applications are filed with the Department of Planning and Land Use. Within 5 days of receipt of a complete application, copies of the application are transmitted to each member of the Fallbrook Design Review Board. The chairperson of the Design Review Board then schedules the item for review at the next available Design Review Board meeting and informs the applicant of the time, date and place for the hearing.

Evaluation of the project by the Design Review Board is limited to the topics contained in this manual. The Review Board makes a recommendation to the applicable County approval authority, citing specific guidelines to which the project conforms or does not conform.

The applicable approval authority also evaluates the project for conformance to this manual, considers the Design Review Board's recommendation, and renders a decision. The decision may be appealed in accordance with the County's appeal procedures. In the event the Review Board's recommendation is not received within 20 days after transmittal of the application, a decision may be made without a recommendation of the Review Board. Upon making a decision, the County should transmit a copy of the decision to the Review Board.

PART 2. COMMUNITY DESIGN OBJECTIVES



Fallbrook residents feel strongly about preserving the agricultural and rural residential character of their community and the quality of living conditions residents now enjoy. The Design Guidelines describe important principles to assure that new development in Fallbrook is designed and built with a strong emphasis on quality, sensitivity to the landscape and respect for the community's Design Objectives.

1. Preserve the character of the existing community landscape by retaining important natural features, land forms and scenic resources.

New development should incorporate existing mature vegetation, drainage courses, topographical features and rock outcroppings into site designs. Existing agricultural features such as groves and orchards which reflect the history of the site and community should be preserved, when possible, to form special elements or incorporated into the open spaces of new developments.

Development on ridge lines is strongly discouraged. The siting of buildings should avoid highly visible locations on the ridge line and should modify existing landforms as little as possible.

2. Preserve and strengthen the "village" character, pedestrian orientation and historic identity of the Town Center.

Fallbrook's village-like Town Center should retain its present character as a traditional American "Main Street." New development in the Town Center should be built to the sidewalk to heighten pedestrian interest and minimize the visual impact of the automobile. Preservation of existing buildings with architectural merit is encouraged, integrating them into new developments when possible. Street tree planting should accompany all new projects in the Town Center. The intent is to create a compact, unified pedestrian shopping district with strong identity and a distinct character, different from suburban, automobile-oriented commercial areas.

3. Unify commercial development outside the Town Center and integrate it into the community landscape, minimizing the impact of signs, parking lots and traffic congestion.

Fallbrook's commercial areas outside the Town Center should avoid the character of commercial strip development - the tendency of each project and site to "stand out" from its neighbors, call attention to its parking lots and signs, and develop multiple driveway entrances on major streets. Fallbrook's emphasis is preservation and enhancement of an outstanding residential community, where commercial development fits "quietly" into the landscape, is compatible in character with nearby residential neighborhoods, and contributes to a unified street character.

The Design Guidelines prescribe a 15-foot deep "Landscaped Edge Zone" along the street edges of all commercial development outside the Town Center. The Edge Zone will help integrate separate developments into a unified street image. Its design is limited to basic elements that reflect Fallbrook's rural "feel" - drought tolerant trees and shrubs of rugged form, landforms and rock placements, low wood fences and stone walls. Signage is to be of limited height and size, carefully-designed and located.

4. Multi-family residential development should contribute to the sense of neighborhood by site planning and architectural design that emphasize the relationship of buildings to the street and adjacent properties.

Fallbrook residents recognize the need for a variety of housing types that accommodate residents with different economic means, lifestyles and preferences. All housing development, however, should contribute to the character of the town and its neighborhoods. Designs that have the character of isolated "complexes" or "projects" are not acceptable, nor are inconsiderate site plans that orient parking lots or rows of garage doors toward streets and neighbors. Instead, multi-family developments should follow a pattern similar to the tradition of older towns, orienting as many dwelling units as possible toward the street, with doors, windows, garden courtyards and porches as the dominant elements in public view.

Multi-family developments must provide adequate private and common usable open space for their residents to enjoy. The Design Guidelines prescribe desirable usable open space standards. Every dwelling unit must have access to private open space. Every development other than senior citizen housing must provide playground space for children. Common spaces such as courtyards, recreation areas and gardens are encouraged. Developer contributions to park and open space funds shall not substitute for on-site open space provisions.

5. Preserve and enhance the quality of scenic roads throughout the Community Planning Area.

Fallbrook's scenic roads are an important element of the community's character and image. Among the most important are Mission Road, Gird Road, Pepper Tree Lane and Live Oak Road, but other lesser roads and streets also contribute to the distinct feel of a rural residential environment. Existing natural features such as land forms, stream beds, rock outcroppings and mature trees should be protected along these routes, with new grading and other man-made interventions minimized. Views from the road to the hills and valleys of the community landscape should also be preserved when siting new buildings and trees. New planting that continues the predominant existing species on a road or street is encouraged, as are other elements such as rustic fences, stone walls or agricultural artifacts that preserve historic character.

PART 3. THE DESIGN GUIDELINES

INTRODUCTION

This part of the Guidelines, is divided into three sections:

A. General Guidelines Applicable to All Development.

B. Guidelines by Development Type and Area.

This section applies to specific development types. In most cases only one set of the Guidelines in this section will apply to a development, though in the case of mixed use developments more than one may apply.

C. Guidelines For Areas With Special Environmental Considerations.

This section addresses Scenic Roads, Hillside Development and Development In Flood Plains. These features are natural elements of the community which contribute substantially to Fallbrook's unique and special character. Developments which occur on property having one or more of these conditions should give extra attention to their preservation.



GIRD ROAD

A. GENERAL GUIDELINES APPLICABLE TO ALL DEVELOPMENTS



A1. SITE DESIGN PROCESS

The quality of site design is the most important measure of a project's impact on the community and will be given first priority in the review of development proposals. Projects should demonstrate sensitivity to both the natural setting and to the neighborhood context. A project should also contribute to the community's design goals.

1. SITE ANALYSIS

• Each development proposal should include a thorough analysis of existing conditions on and adjacent to the site. A proper analysis will include a careful examination of a site's physical properties, its amenities, special problems, character and an examination of the neighboring environment. The analysis will assist the Design Review Board in evaluating the proposed development's relationship to existing conditions, neighboring properties and the community at large.

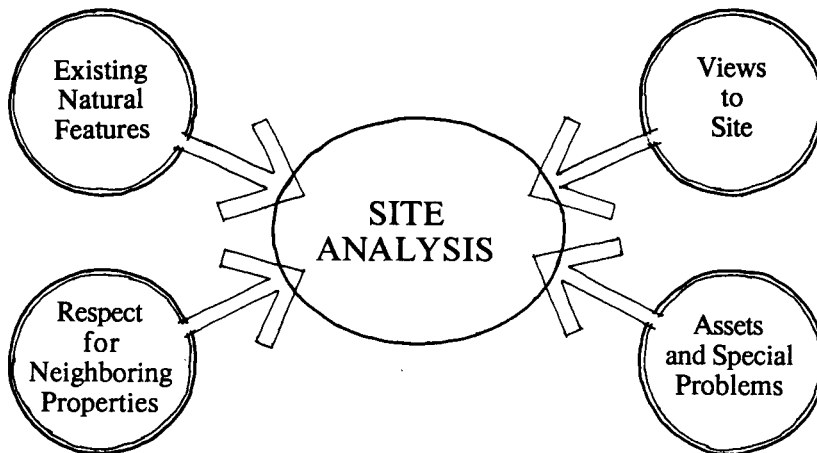

SITE ANALYSIS CONSIDERATIONS

• Although the steps in a thorough analysis will vary with the unique situation of each site and project, the following information is normally needed (see Part 4 for specific Design Review Application requirements):

- **Basic Site Data:** boundaries and dimensions; location of adjacent roads, sidewalks, and rights-of-way; location of setback lines and easements; existing structures and other built improvements.
- **Existing Natural Features:** location, size and species of trees and other important vegetation; topography, with areas of slope over 25% highlighted; patterns of surface drainage; location of flood plain; significant rock outcroppings; soil capability; ground water location; and other important features that are either amenities or potential hazards in development.

- **Neighboring Environment:** views to the site; land use and site organization of neighboring properties; form and character of neighboring buildings; important site details on neighboring properties which can be seen from the street (such as stone walls, fences and organized plantings). The Design Review Submittal Requirements include photographs of the site and neighboring properties.

2. GENERAL SITE DESIGN CRITERIA

A new development should establish a compatible relationship to the community as well as to neighboring properties:

- Demonstrate an overall design integrity and a serious attempt to contribute to the beauty and harmony of the community.
- Contribute to the community's design objectives.
- Develop compatible relationships to the land forms, building placement, and existing open spaces of neighboring properties.
- Respect the existing views, privacy, quiet, sun and light exposure of neighboring properties.
- When land use or development patterns require a project to be different from its neighbors, provide a transition from existing to new development by careful placement and massing of buildings, well-designed planting patterns and other means.

3. PRESERVATION OF EXISTING NATURAL FEATURES

Development proposals should demonstrate an effort to retain significant existing natural features characteristic of the community's landscape. Existing topography and land forms, drainage courses, rock outcroppings, vegetation and views should be recorded in the Site Analysis and incorporated, to the maximum extent feasible, into the future development of the land.

a. Mature Trees

- All mature trees should be retained when feasible. This will require careful judgment weighing the value and hierarchy of all natural features, the size and species of the tree, and the developer's program for the site. This Guideline is not meant to preclude removal of noxious or undesirable trees.
- Existing oaks over 8 inches in diameter are considered significant resources to be preserved. See Guideline A2. "Preservation of Significant Trees" for definitions and descriptions.

b. Topography

- Demonstrate an effort to minimize grading and alteration of natural landforms.
- Minimize potential problems created by building in areas of excessive slope, soil with poor bearing capacity, slide potential, flood plain or other hazards.
- Building pads should be sited within the zoned setbacks and are to disturb the natural contours as little as possible. Balancing of cut and fill areas is encouraged. See Guideline A2, "Preservation of Significant Trees", for grading techniques necessary for the preservation of existing trees.

c. Drainage

- Minimize potential surface drainage problems on neighboring properties and provide adequate drainage on-site.
- Natural drainage courses are to be preserved as close as possible to their natural location and appearance. “Dry stream” effects which move the water over the property are preferred over channeling or undergrounding methods.

4. CIRCULATION AND PARKING

- Provide a clearly organized circulation plan for automobiles, pedestrians and service vehicles.
- All developments are strongly encouraged to reduce the number of driveway entrances on to public streets. This is especially critical for commercial developments as a means of reducing traffic congestion. Vehicular linkages between neighboring developments, through common entrance driveways, linked driveways and common service/delivery areas, are strongly encouraged.
- Parking and service areas should be located and landscaped to minimize public view from roads and neighboring properties.
- On hillside sites, roads and streets should generally follow existing land contours.

5. INTERNAL SITE DESIGN

- Buildings and open spaces should be organized to take advantage of the spaces between buildings as opportunities for outdoor activities, as transitions between indoors and outdoors, and as potential points of “focus” for the development.
- Buildings and building groups should strive to form compact clusters to economize in the use of land and create larger open spaces on the site.
- The site plan and planting should consider climatic conditions to provide shade from summer sun, natural ventilation and other measures to maximize energy efficiency and human comfort.

A2. PRESERVATION OF SIGNIFICANT TREES

The community recognizes that native oaks and other significant trees are important historical, aesthetic and ecological resources that contribute to the distinctive character of Fallbrook. The purpose of this Guideline is to create favorable conditions for the preservation and propagation of this unique, irreplaceable plant heritage.

1. DEFINITIONS

- “Significant tree” shall mean any tree which is more than 12 inches in diameter as measured four and one-half feet (4’-6”) above the root crown; or, any tree with a total diameter of any two trunks of at least 16 inches as measured four and one-half feet (4’-6”) above the root crown.
- “Oak tree” shall mean any tree of the quercus genus more than 8 inches in diameter as measured four and one-half feet (4’-6”) above the root crown; or any such tree with a total diameter of any two trunks of at least 12 inches as measured four and one-half feet (4’-6”) above the root crown.

2. GUIDELINES

- Site development plans should demonstrate a diligent effort to retain as many native oak and other significant trees as possible.

a. Criteria For Removal

- In assessing the number of trees and specific trees that may be removed, the applicant and Design Review Board should consider the following criteria:
 - 1) The condition of the oak or other significant tree with respect to disease, danger of falling, and the proximity to existing or proposed structures. Should debate over the health of the tree arise, a licensed nurseryman should be consulted at the expense of the applicant.
 - 2) The necessity to remove an oak or other significant tree in order to construct proposed improvements to prevent economic hardships to the owner of the property.
 - 3) The topography of the land and the effect of oak and other significant tree removal on erosion, soil retention, and the diversion or increased flow of surface waters.
 - 4) The number of oak or other significant trees existing in the neighborhood. Decisions should be guided by the contribution of significant trees to the visual character of the neighborhood.
 - 5) Good forestry practices, such as the number of healthy oak or other significant trees which a given parcel of land or area can support.

b. Where Significant Trees Have Been Removed

- When oaks or other significant trees must be removed, replanting with the same species is recommended. Open spaces, recreation areas, and terraces are appropriate areas for oaks. Parking lots and lawn areas are appropriate areas for many of the other significant trees. Because oaks grow slowly, plant 24" box trees as replacements. Other significant trees may be replaced with 15 gallon sized plants. Designers of each site should take responsibility for the correct site conditions required for each type of tree.

c. Techniques For The Preservation Of Oaks

- The most critical issue in the care and maintenance of an existing oak is the altering of conditions under which that tree has grown for possibly 200 to 300 years. "Altering" includes changing the grade within the drip line, changing watering practices from natural rainfall to supplemental irrigation, changing the leaf litter beneath the trees, changing drainage patterns, and compaction of soil around roots caused by heavy equipment.

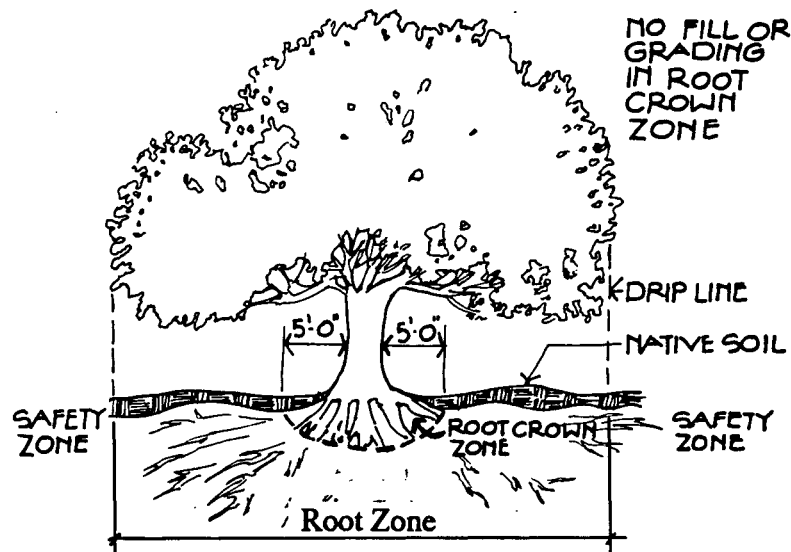

- Should changes of grade be necessary, the following steps may be taken:
 - 1) Establish radius of existing root system by using soil probes or equivalent. This establishes a Root Crown Zone within which there should be no grading. New development may require gradual root pruning. Consult a nurseryman for proper techniques. Root pruning enables roots to be cut for a lowering of the natural grade. Under no circumstances should soil be added in the Root Crown Zone, but soil may be added over the Root Zone if the root crown is protected by retaining devices.
 - 2) Overwatering oaks during the summer creates conditions favorable to root rot and oak root fungus. Besides reducing water to the root zone, draining water off the root crown quickly is vital for the health of the tree. Sloping soil away from the root crown improves drainage by creating rapid water runoff. In heavy soils, such as clays, leach lines installed within drip line and extending out to drainage courses may be necessary to increase drainage. In all cases, the goal is to duplicate the native conditions under which the oak has lived. Essentially, if the existing conditions were dry, leave them dry; if they were wet, leave them wet.

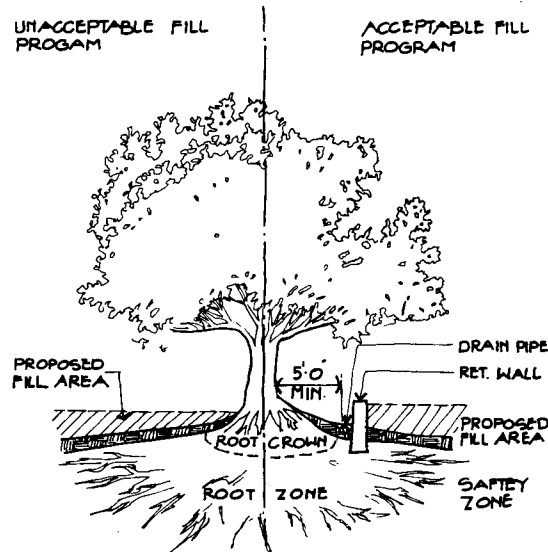

3) Leaf litter is the accumulation of live and decaying leaves at the base of a tree. In the case of oaks, this litter contributes to a cool atmosphere for root growth, and an acid condition resulting from the decaying of the leaves. When possible, leave the natural litter in place.

4) Poor drainage caused by a change in grade or compaction produces constant moisture at the base of the trunk. Growing lawns beneath oaks also frequently produces poor drainage. This problem can be averted by using other ground covers, sloping the natural grade away from tree, and diverting sprinklers away from trunk. A dense turf or compacted soil can greatly reduce aeration in the soil. Reduced aeration plus excessive water favors development of harmful soil organisms, such as oak root fungus, which may be present in an inactive stage until stimulated by favorable growing conditions or even mechanical root injury.

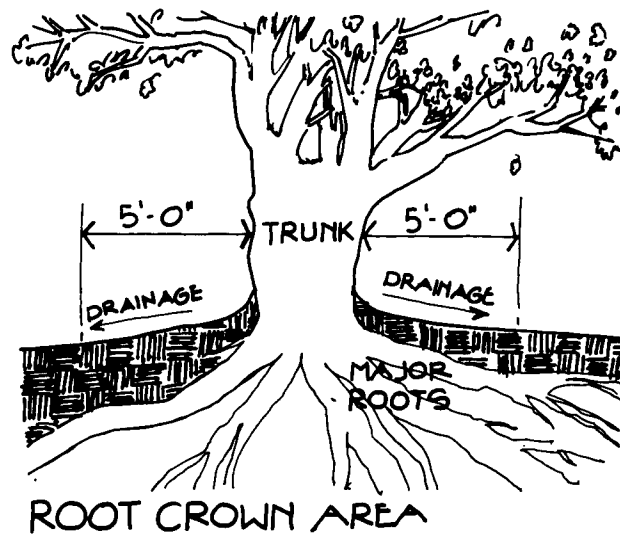

In summary, native oaks are extremely sensitive plants. Minimal grade changes within the drip line can drastically affect aeration of the roots and drainage around the root crown. Avoid changes of grade, if at all possible. Avoid summer irrigation which would produce constant moisture at root crown. Treat oaks with the care they deserve!

A3. OLD AND NEW DESIGN RELATIONSHIPS

All development proposals should show evidence of harmony with the site plan, arrangement of building forms and landscape design of neighboring properties.

The degree to which neighboring sites and buildings must be considered in the design of a new project will depend upon the value, architectural quality and estimated tenure of improvements on the neighboring property, as well as the particular requirements of the new project. While a firm rule for design is not possible, every new proposal should demonstrate that it has considered the contextual influences of neighboring properties and has made a diligent effort to orchestrate careful relationships between old and new.

Drawings, models and/or other graphic communication techniques presented to the Design Review Board must show neighboring buildings and important features of adjacent sites. Existing features should be shown in sufficient detail to enable evaluation of the relationship of the proposed development to its context. Perspective views of the proposed project and its immediate neighbors, as seen from the street, sidewalk or other public place, are encouraged.

1. SITE PLANNING

- The site organization should respect the arrangement of buildings, open spaces and landscape elements of adjacent sites. When possible, buildings and open spaces should be located for mutual advantage of sunlight, circulation and views.
- When feasible, new commercial projects should be linked to adjacent projects to encourage internal circulation by pedestrians and automobiles. This will provide for architectural consistency, pedestrian convenience and reduced traffic loads on adjacent streets. The method of linkage will depend on specific conditions of each site and project. The linkage could be as simple as a connecting sidewalk, or as complex as integral driveways, covered walkways and integrated landscaping. Applicants are encouraged to be creative in their solutions to this issue keeping in mind the intent.

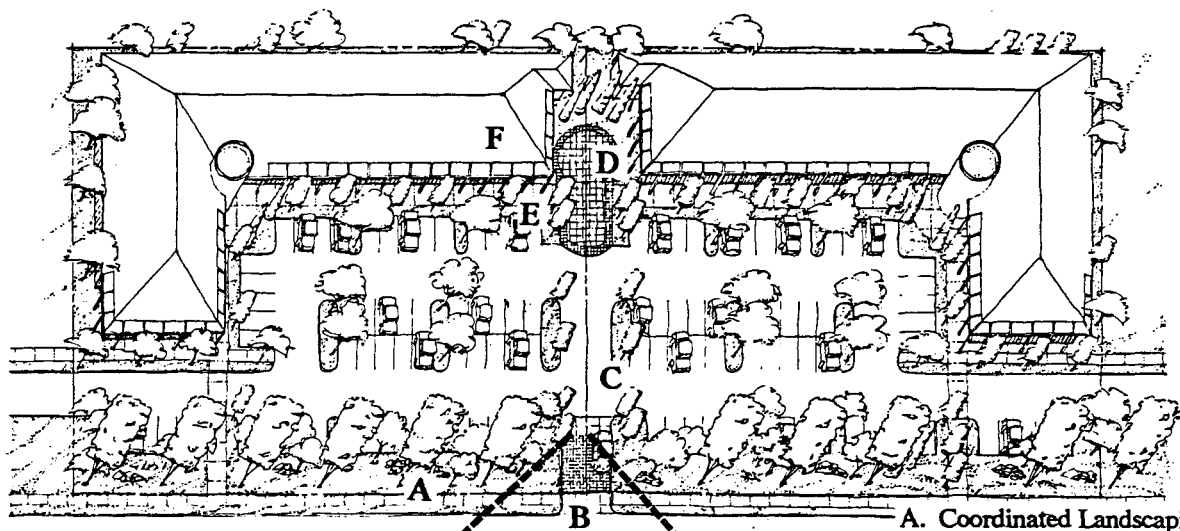

LINKAGES

- A. Coordinated Landscaping
- B. Shared Driveway
- C. Aligned Parking Lot Drives
- D. Common Pedestrian Open Space
- E. Connected Internal Sidewalks
- F. Similar Building Scale and Design

- Sidewalks in front of new buildings are encouraged to have a paving material and pattern that is either representative of a predominant pattern already existing in the neighborhood or one that reflects an extension of the building's design character.

2. ARCHITECTURAL DESIGN

- Efforts to coordinate the actual and apparent height of adjacent structures are encouraged. This is especially applicable where buildings are placed very close to each other, as they are in the Town Center. It is often possible to adjust the actual height of a wall, cornice or parapet line to match that of an adjacent building. Similar design linkages can be achieved to adjust the apparent height by placing window lines, belt courses or other horizontal elements in a place or pattern that reflects the same elements on neighboring buildings.

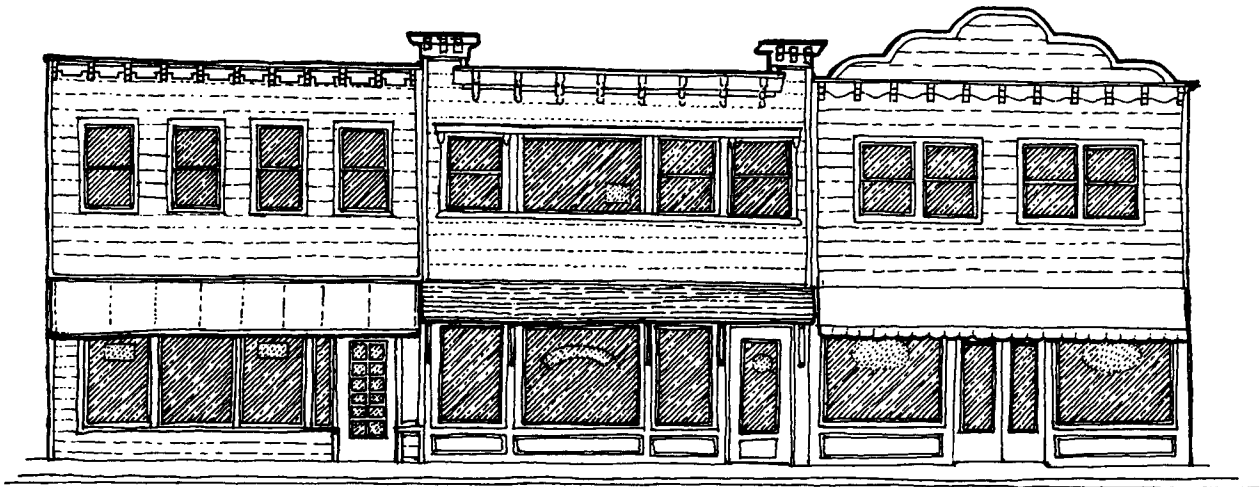

BUILDINGS RELATED BY COMMON OR COORDINATED FACADE ELEMENTS

A4. ARCHITECTURAL CHARACTER

- Recognize the linkage potential of old and new projects.
 - Respect the scale of the community with regard to the apparent height and width of new buildings.
 - Building form, mass and elevations should be articulated to create interesting roof lines, shadow patterns and architectural detailing.
 - Buildings should incorporate natural landscape features as design elements.
-

This Guideline applies to all development subject to Design Review. More specific guidelines for the Town Center are given in Guideline B1.

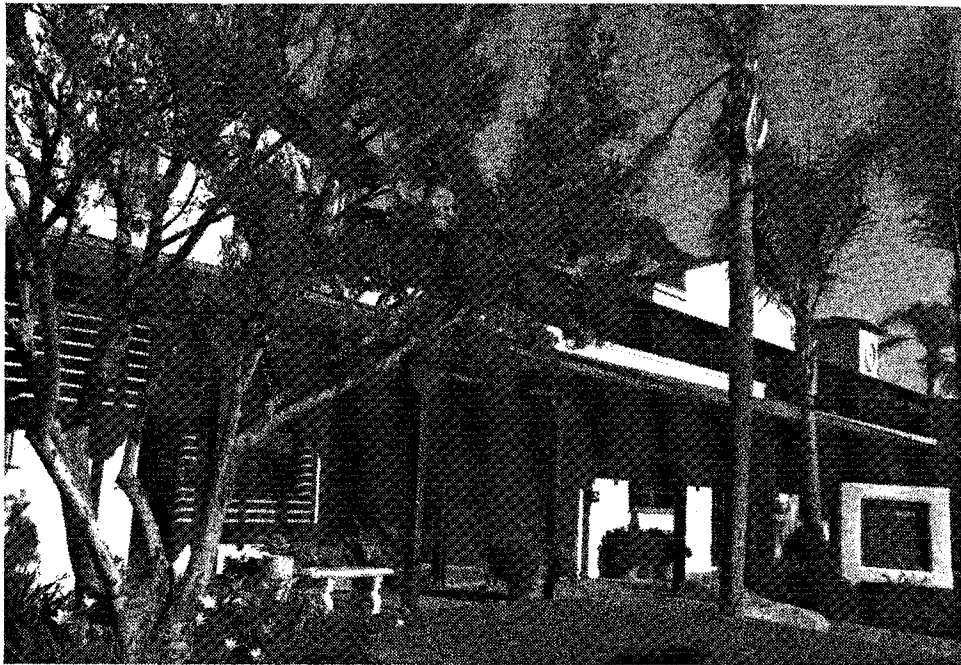

1. BUILDING FORM

- On principal elevations, large or long continuous wall planes should be avoided. As a general rule, building elevations over 50 feet in length should incorporate changes in plane and architectural features that provide visual interest, including strong areas of shade and shadow.

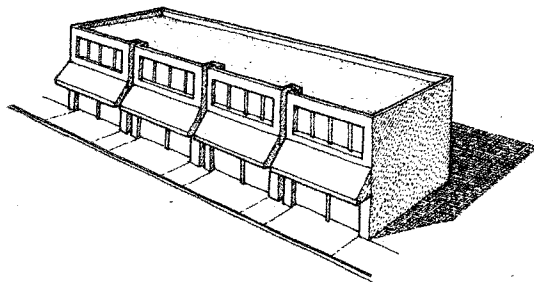

DESIRED APPARENT WIDTH

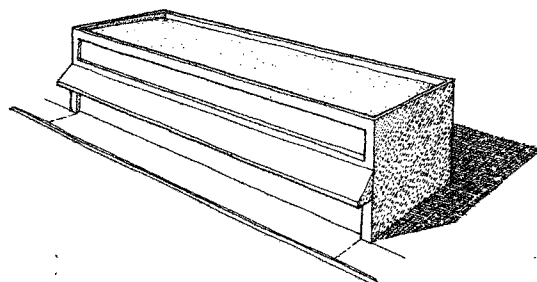

NOT DESIRED

- The visual contrast of light and shadow gives buildings depth and substance. Every building should have some shadow relief. Offsets, projections, roof overhangs and recesses all may be used to produce areas of shade and shadow.

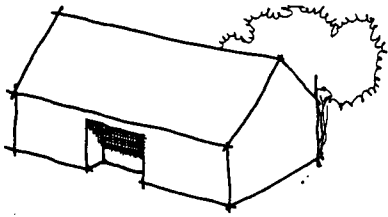

RECESSED AREAS
PROVIDE SHADOW RELIEF

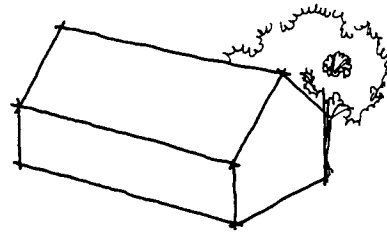

NO SHADOW RELIEF

- Changes in roof pitch orientation should be accompanied by plan offsets. Similarly, abrupt changes in adjacent heights require plan offsets to soften appearance.

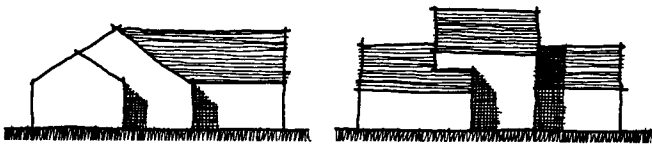

RECOMMENDED PLAN OFFSETS

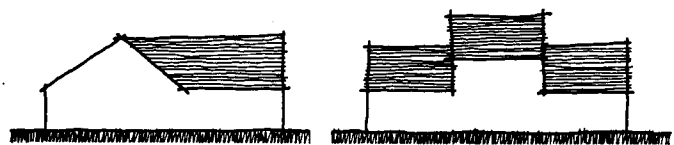

NOT RECOMMENDED

- Buildings over two stories in height are discouraged in Fallbrook. In the event a building over two stories is necessary, the building should provide a vertical setback between the second and third floors to reduce the “apparent” height to two stories.

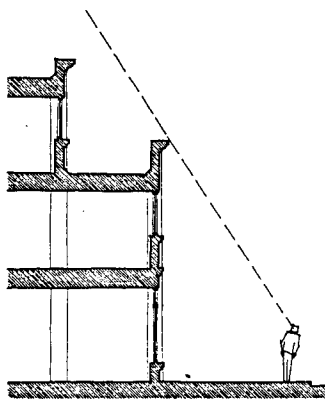

APPARENT HEIGHT

2. MULTI-BUILDING PROJECTS

Multi-building developments should strive for a consistency of design among separate structures.

- Facades and roof lines facing streets, parking areas and residential neighbors should be consistent throughout the development in design, color and materials.
- Rear facades, if visible from public streets or neighboring properties, should be finished in a quality, color and material similar to the principal sides of the building(s).

3. BUILDING MATERIALS

- Material changes are more effective if they do not occur in the same plane. Instead they should intersect with an architectural element, such as a chimney, projection or pilaster.

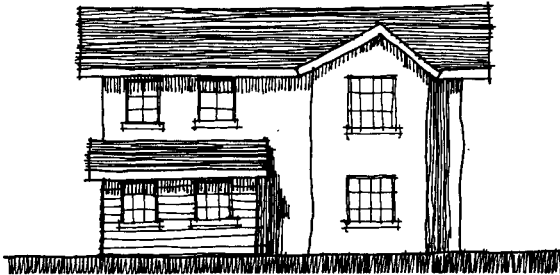

RECOMMENDED MATERIAL CHANGES

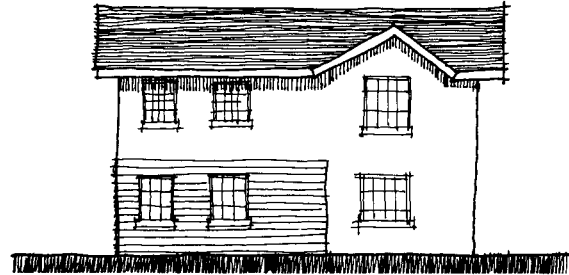

NOT RECOMMENDED

- Architectural elements, signage and other facade elements should be integrated into the design of the facade.
- The following is a list of materials whose use is encouraged:
 - Cement plaster (stucco) over masonry or wood frame.
 - Exposed timber structural members.
 - Brick, adobe and native stone.
 - Concrete and concrete masonry with textured surfaces and integral color.
 - Wood siding.
- The following is a list of materials whose use is discouraged:
 - Large areas of glass, unless located at pedestrian level for store fronts.
 - High contrast color glazed masonry except for small areas of detail.
 - Glass curtain walls.
 - Synthetic materials made to resemble masonry.

4. ROOF FORMS

- Outside the Town Center, gabled, hip and shed roof forms at a moderate to steep pitch are encouraged. Generous overhangs to create strong shadow lines are also encouraged.
- Wide eaves with boards are encouraged to create deep shadows on building walls and to reduce the amount of sunlight striking glass surfaces.
- The following is a list of roof materials whose use is encouraged:
 - Clay tile.
 - Concrete tile.
 - Composition shingles with a shadow line.
 - Fire treated wood shakes and shingles.
- The following is a list of roof materials whose use is not recommended:
 - High contrast color, brightly colored glazed tile or highly reflective surfaces.
 - Corrugated or galvanized sheet metal.

- Extensive flat roofs should be avoided. When flat roofs are necessary in large commercial and industrial buildings, they should incorporate shed roofs, trellises or loggias to scale down a structure and provide shadow relief.

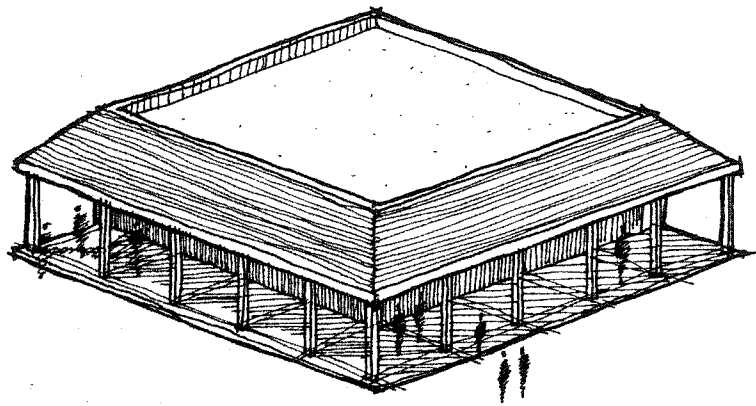

SCALED DOWN FLAT ROOF

5. ENTRANCES, WINDOWS AND DOORS

- Primary building entrances should be emphasized so that their location is apparent and clear. Porches, loggias and canopies are helpful to call attention to an entrance.
- Entries and entry doors may be designed as a focal point of the front elevation. Detail treatments at doors and entries can range from the use of tile, color accents, exposed timbers or combinations of architectural features such as pediments, moldings and small roofs which can also provide protection from weather.
- Windows and doors should be deeply recessed to create strong shadow lines.

6. EXTERIOR SPACES

Most buildings can be enhanced by outdoor spaces such as balconies, verandas, patios and loggias. These spaces should be large enough to accommodate outdoor activities, and should not simply be decorative elements.

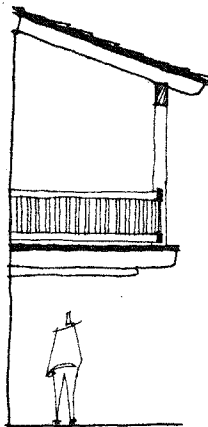

VERANDA



PATIO

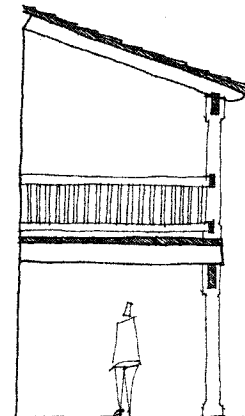

LOGGIA

7. WALLS, FENCES AND ACCESSORY STRUCTURES

- High solid fences and walls along public streets can have a negative impact on the surrounding neighborhood and should be minimized. When solid walls are used to buffer traffic noise, as is sometimes necessary in residential projects along major streets, the walls should reduce their monotonous tendency by providing a change of plane at a minimum of 50 foot intervals. Fences and walls over 3 feet high which face public streets should provide a fully landscaped buffer at least 5 feet deep on the street facing side of the wall.
- Walls on sloping terrain should be stepped at regular intervals to follow the terrain.

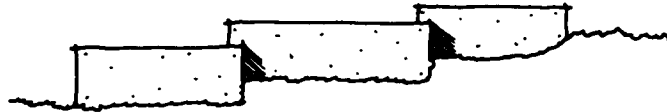

STEPPED WALL TO FOLLOW TERRAIN

- The following is a list of wall and fence materials whose use is encouraged:
 - Native stone.
 - Masonry with cement plaster finish.
 - Wood framing with cement plaster finish.
 - Detailed wrought iron.
 - Wood.
 - Brick.



STONE WALL

- The following is a list of wall and fence materials whose use is discouraged:
 - Chain link or open wire, except when heavily screened by landscaping. See Appendix A for shrub selection.
 - Corrugated metal.
 - Bright colored plastic or plastic coated materials.
 - Reed materials.
- Accessory structures should be designed to be compatible with adjacent buildings. Patio covers, green houses, storage spaces and other ancillary structures should be located and designed to respect the views and other special conditions of adjacent properties.

8. SITE DETAILS AND FURNISHINGS

- The design, selection and placement of all site furnishings such as tables, benches, bollards and trash receptacles should be based on consideration of the overall concept of the site and architectural character of the total project.

A5. LANDSCAPE CHARACTER

The citizens of Fallbrook take pride in their natural setting and agricultural heritage. The rugged foothills which are interwoven throughout the community are dotted with orderly rows of citrus and avocado groves. Views into scenic valleys provide vistas of ranches nestled there. It is the quality and character of this landscape which community members want to preserve and see interpreted in new construction throughout Fallbrook.



1. DESIGN CONCEPTS

There are two overall principles which are the foundation of the landscape design guidelines:

First is the preservation and reinforcement of the qualities of the natural and agricultural environment loved by community members.

- The agriculture practiced in Fallbrook is varied, but citrus and avocado groves predominate. There is an overwhelming presence of trees: dense, fragile, flowering, tall, evergreen, deciduous, orderly, rugged. The Guidelines reflect this character by encouraging densely planted trees with these characteristics along community streets and within all development.
- To compliment the trees and enhance the rural quality of the community, the Guidelines encourage masses of shrubs planted beneath trees. These shrubs will provide flower color, fragrances, and important screening considerations. Low shrubs

can be used in foreground plantings and higher shrubs behind for screening. Because shrubs are more drought resistant than shallow rooted ground covers, the use of ground covers is generally not recommended for the Fallbrook landscape. In their place, creeping shrubs should be used to act as a “ground cover” and to achieve a longer lasting result.

- Because expanses of turf grasses are more commonly used in urban and suburban gardens they are discouraged for use in Fallbrook’s rural setting except in parks or other active use areas. The goal is to maintain an environment unique to Fallbrook. The Guidelines encourage creativity in the design of new plantings which follow this goal.

The second, but equally important consideration, is Fallbrook’s water supply. Water will become scarce and more expensive in future years. In order to preserve and extend the life of the beautiful, lush environment loved by the Fallbrook community, plant materials must be selected carefully. Appendix A. “Plant Selection Guide” at the end of this booklet lists suggested plant species and their recommended uses. Plants have been chosen based upon the following criteria:

- Water needs throughout the year drought resistant plantings are encouraged.
- Appropriateness for climate zones.
- Species considerations for: form, flowering characteristics, texture, and size appropriate to Fallbrook.
- Maintenance needs, based on locations.

2. GENERAL GUIDELINES

- Site areas not used for buildings, parking or other designated functions should be planted.
- All landscaped areas should have an underground irrigation system capable of sustaining good plant growth. Automatic systems are encouraged.
- All planting beds should be mulched with an organic mulch of at least 2 inches in depth.
- When existing trees are to be retained in site plans, they may be counted toward tree planting requirements. New planting requirements may be further adjusted to reflect the size and density of existing trees and shrubs.

3. PUBLIC RIGHT-OF-WAYS

All public right-of-way areas between a newly developed property and the existing sidewalk or street edge should be fully landscaped. Trees should not be planted in the right-of-way.

A6. DESIGN FOR CLIMATE AND ENERGY CONSERVATION

All development projects should strive for site planning, planting and building design which reduces energy consumption and provides more comfortable indoor and outdoor living spaces.

- Protected courtyards, porches, arcades, loggias, verandas and overhangs are effective means of shading exterior wall surfaces and windows from direct sun exposure. These elements are easily added to buildings as temperature-moderating elements. An additional benefit is their ability to add visual character to the building.

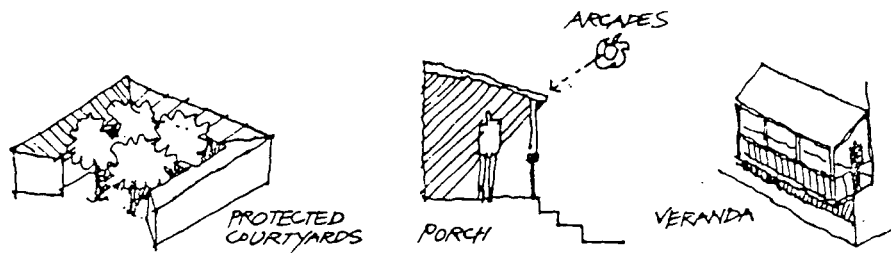

COURTYARDS, PORCHES AND VERANDAS

- Deciduous trees used on the south and west sides of a building can provide shade in summer while allowing sun penetration in winter. All trees should be drought tolerant.

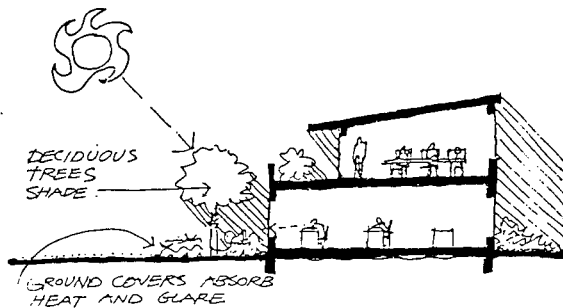

TREE SHADING

- Roof overhangs on south-facing walls offer effective protection of window areas from summer sun while admitting lower winter sun rays.
- South-facing courtyards may be used to create protected outdoor spaces, giving the site a more favorable microclimate for year-round activities.

A7. SIGNAGE

Signs in Fallbrook should be designed to communicate in a simple, clear and uncluttered manner. They should be in character with the neighborhood they are in and the buildings and uses they represent.

1. GENERAL DESIGN CRITERIA

- All signs should be a minimum size and height to adequately identify a business and the products or services it sells.
- All monument signs should be kept as low to the ground as possible.
- Signage design should be carefully integrated with the site and building design concepts to create a unified appearance for the total development. Within a development, signage should be consistent in location and design.
- Signs should be carefully located for safety so as not to block driveway views of oncoming traffic.
- Illumination should be projected onto the sign face. The light source should be fully shielded from view.
- Color of all signs and sign components should be limited to 3 in addition to black and white.
- Typefaces should be chosen for their simplicity and clarity. Signs on older buildings are encouraged to use a typeface which was used in the period when the building was built.
- To calculate the size of a sign, measure:
 1. The area of the box or outline which contains the sign, or
 2. In the case of unboxed letters or symbols, the area of the smallest rectangle which would enclose all of the letters or symbols.

A diagram showing the text "Fallbrook Citrus Company" enclosed within a double-lined rectangular border. A curved arrow points from the text to the label "Measure The Sign Box" below.

Measure The Sign Box

MEASURING A BOXED SIGN

A diagram showing the text "Fallbrook Citrus Company" with a dashed rectangular border around it. A curved arrow points from the text to the label "Measure The Imaginary Box" below.

Measure The Imaginary Box

MEASURING AN UNBOXED SIGN

3. Only one face of a double-faced sign with parallel opposing faces, and bearing identical copy, shall be used in calculating sign area. Signing and illumination shall be on two opposing faces only.
- Sign posts and other structural elements should be made of wood or metal with a white, black or natural stain finish. Reflective or bright colors should be avoided.

- No sign, other than a sign installed by a public agency, should be placed in the public right-of-way on sidewalks or streets, except signs which hang over sidewalks in the Town Center. All overhead signs should clear adjacent sidewalks with a minimum headroom of 7 feet, and should project no more than 4 feet into a public right-of-way.

- No sign should be allowed above the highest portion of the building.

2. RECOMMENDED SIGN TYPES

The following types of signs are generally recommended by the Guidelines. Sections following indicate further recommendations based on uses and districts.

- **Awning Valance:** A sign or graphic attached to or printed on an awning's valance
- **Monument :** A sign supported by one or more uprights or braces on the ground, not exceeding 4 feet in height.
- **Hanging:** A sign attached to and located below any eave, canopy or awning.
- **Kiosk:** A small freestanding structure which has one or more surfaces.
- **Projecting:** Any sign which projects from and is supported by a wall of a building with the display surface of the sign perpendicular to the building wall.
- **Wall:** A sign affixed directly to an exterior wall or fence.
- **Window:** A sign affixed to or behind a window, no larger than 25% of the window on or behind which it is displayed.
- **Single Pole Hanging Sign:** A sign which is suspended from a horizontal arm which is attached to a pole no higher than 6 feet in height.



AWNING VALANCE

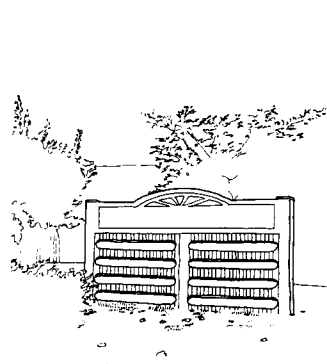

MONUMENT

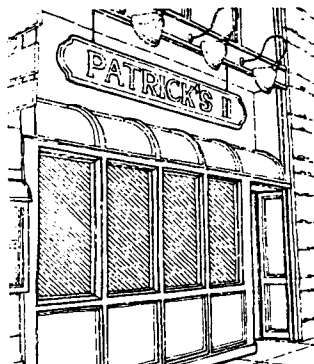

HANGING

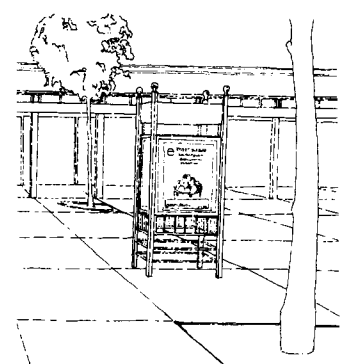

KIOSK

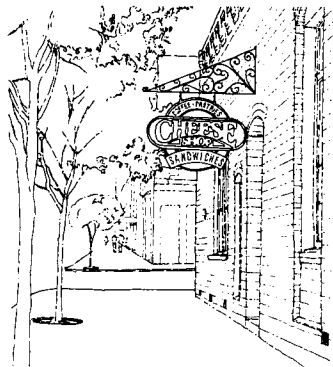

PROJECTING

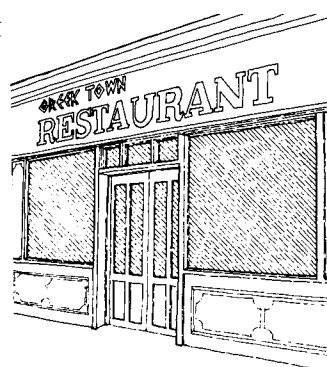

WALL

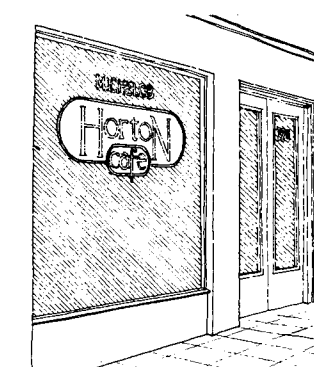

WINDOW

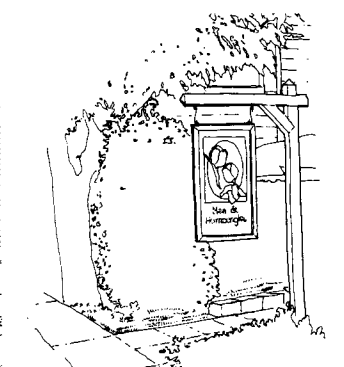

SINGLE POLE HANGING

3. SIGN GUIDELINES BY USE

a. All Commercial and Industrial Development

- Letter and symbol height should be limited to a maximum of 8 inches.
- Where frontage is defined as the length of the building(s) facing the principal street of the development (each project can only have one frontage):
 - 1) For frontages up to 100 lineal feet, the total sign area should be limited to one square foot of sign area per linear foot of building frontage, to a maximum of 65 square feet.
 - 2) For frontages over 100 lineal feet, the total sign area should be limited to 3/4 square foot of sign area per linear foot of building frontage, to a maximum of 90 square feet.
 - 3) For projects with more than one tenant:
 - a) One sign to identify the complex allowing one square foot of sign area per lineal foot of total project frontage up to 75 square feet and
 - b) For each individual tenant on a public street or private drive, 1/2 square foot of sign area per lineal foot of tenant frontage, to a maximum of 25 square feet .
 - c) One building directory sign not exceeding 10 square feet in size may be allowed at each public entrance.
- Sign types which are recommended for Commercial and Industrial developments:
 - Awning Valance.
 - Monument.
 - Hanging.
 - Kiosk.
 - Projecting.
 - Wall.
 - Window.
 - Single Pole Hanging.
- Kiosk signs should be limited to 8 feet in height and only used on private property and incorporated into the design of a courtyard or other pedestrian space.

b. Town Center Commercial Development

- Sign types and guidelines which are recommended for the Town Center include all the types and guidelines listed for Commercial and Industrial developments except monument signs.

c. Multi-Family Residential Development

- There should be no more than one sign per multi-family residential development entry from a public street or road.
- Sign area should be limited to 10 square feet for projects of less than 25 dwelling units, and 25 square feet for projects with 25 or more dwelling units.
- Sign types which are recommended: Wall, Hanging, Single Pole Hanging and Monument.

4. PROHIBITED SIGNS

- The following signs should not be used in Fallbrook:
 - Roof and parapet signs.
 - Internally illuminated plastic signs. Other plastic signs are discouraged, except where plastic is used only as raised letters.
 - Back lit signs which appear to be internally illuminated.
 - Pole signs over 6 feet high.
 - Portable or mobile signs.
 - Signs which cover or interrupt architectural features.

A8. SITE LIGHTING

Lighting should be used efficiently to aid safety, security and to compliment architectural character without intrusion into adjacent properties, roadways and the night sky.

1. GENERAL REQUIREMENTS

- All lighting shall, at minimum, follow San Diego County Zoning Ordinance Division 6322.
- Limit the amount and intensity of lighting to that necessary for safety, security and to compliment architectural character. Lighting which interferes with the character of the surrounding neighborhood is not acceptable.
- Lighting which is visible from adjacent properties or roads must be indirect or incorporate full shield cut-offs.
- Service area lighting should be designed to avoid spill over into adjacent areas.
- Special consideration must be given to light pollution which could have a negative impact on the Palomar Observatory.

2. PARKING AREA LIGHTING

- For commercial parking areas overhead lighting should be mounted at a maximum height of 20 feet above the paved surface.
- For residential parking areas, overhead lighting should not be mounted at a height in excess of 15 feet. The placement of lighting in residential parking areas should avoid interference with bedroom windows.

3. WALKWAY, GARDEN AND PEDESTRIAN AREA LIGHTING

- Overhead fixtures used for pedestrian areas should be limited to heights between 8 and 12 feet.
- Overhead lighting of walkways should be located so that light patterns overlap at a height of 7 feet to assure full illumination of a person's body.
- Along walkways, low-level lighting in the form of bollards or fixtures mounted on short posts is encouraged. When this type of lighting is used, fixtures should be placed to minimize glare. Shatter proof coverings are recommended. Posts should be located to avoid hazards for pedestrians or vehicles.

A9. BUILDING EQUIPMENT AND SERVICES

Carefully locate and design building equipment and services to minimize visual impacts on public streets and neighboring properties.

- Where alleys exist locate all service areas, delivery entrances, loading docks and refuse facilities off of the alley.
- In larger commercial developments, service and loading areas should be separated from main circulation and parking areas. The development of separate buildings in larger commercial projects does not exclude them from the requirements of screening trash, loading or service areas.
- Trash containers and outdoor storage areas should be screened from view from public streets, pedestrian areas and neighboring properties. The screen for the trash containers should be designed to be compatible with architectural character of the development and be of durable materials.
- Locate utility meters in service or areas or in screened areas.
- Exterior surface mounted utility conduit and boxes should be kept to a minimum. Where they do exist, they should be designed, painted or screened to blend in with the design of the building to which they are attached.
- Mechanical equipment, solar collectors, satellite dishes, communication devices and other equipment should be concealed from view of public streets, adjacent properties and pedestrian oriented areas.
- Roof mounted equipment should be screened from view from adjacent roads, properties and pedestrian areas. Special attention should be given to changes in elevation which may provide a view down to a roof. In this case enclose the equipment in a screened shelter or design the layout of exposed equipment in an orderly fashion with consideration given to painting them to be compatible with other visible colors on the roof.
- Where solar panels are attached to buildings they should be integrated into the architectural design of the building. Solar panels which are not attached to buildings should be integrated into the landscape design by using berms, natural slopes or similar devices. Where solar panels cannot be integrated into the landscape design they should be screened from view with fences and/or planting. All plumbing and storage tanks associated with solar panels should be concealed from view.
- Screening devices (roof top and ground level) should consider the following elements:
 - Architectural screens should be an extension of the development's architectural character.
 - Screen walls should be constructed of low maintenance and durable materials which are consistent with the main building's materials.
 - Landscaping should be used in conjunction with building materials to complement ground level screening devices.

A10. PRESERVATION OF HISTORIC BUILDINGS

The community of Fallbrook has a respectable and memorable role in the history and development of San Diego County. This history is recorded, in part, in many of the built structures still remaining from Fallbrook's early years.

- New development should recognize, respect, preserve and be compatible with existing significant built elements of Fallbrook's history.
-

A building exhibiting historic character from the period in which it was built can substantially contribute to the character of a new development. To what degree a building should be retained will depend on which of the following 3 categories it falls into:

1. In some cases an existing structure may already be a Designated Historic Site or may be in a Designated Historic District. In this case there are existing procedures and laws for pursuing renovation and new construction. The Planning Department staff for the San Diego County Historic Site Board should be contacted immediately for assistance. Their offices are located in the San Diego County Department of Planning and Land Use.
2. In other cases a site may not be designated, yet it may be suspected of being a significant part of Fallbrook, California or United States history. If a site is suspected of being historically important the following steps should be taken:
 - Contact Planning staff for the San Diego County Historical Site Board for input and direction.
 - Research to establish validity of the site's historic role.
 - Nominate the site for Historic Registration if it so merits.
 - Incorporate the historic site and qualities into new improvements and development per San Diego County Zoning Ordinance Division 5700.
3. The third possibility is that a building or structure exhibits a good deal of the character of a period but does not necessarily qualify as a Historic Site for purposes of designation. This does not, however, mean that an older building cannot contribute to the historic continuity of the community.
 - All older buildings which retain much of their original design character should be retained and should have all alterations or additions done with Compatible Uses and Compatible Designs as described in the San Diego County Zoning Ordinance Division 5718. The Secretary of the Interior's "Standards for Rehabilitation and Guideline for Rehabilitating Historic Buildings" published by the U.S. Department of the Interior, National Park Service, should be reviewed and used.
 - New buildings which are built on the same site as, or adjacent to, older buildings of substantial historic character should be designed to be respectful of the older buildings. While not mimicking the older buildings, new structures should consider the compatibility of details, materials, textures, colors and landscape features. These elements, and others, are discussed in greater detail in Guideline A3. "Old and New Design Relationships."

B. GUIDELINES BY DEVELOPMENT TYPE AND AREA

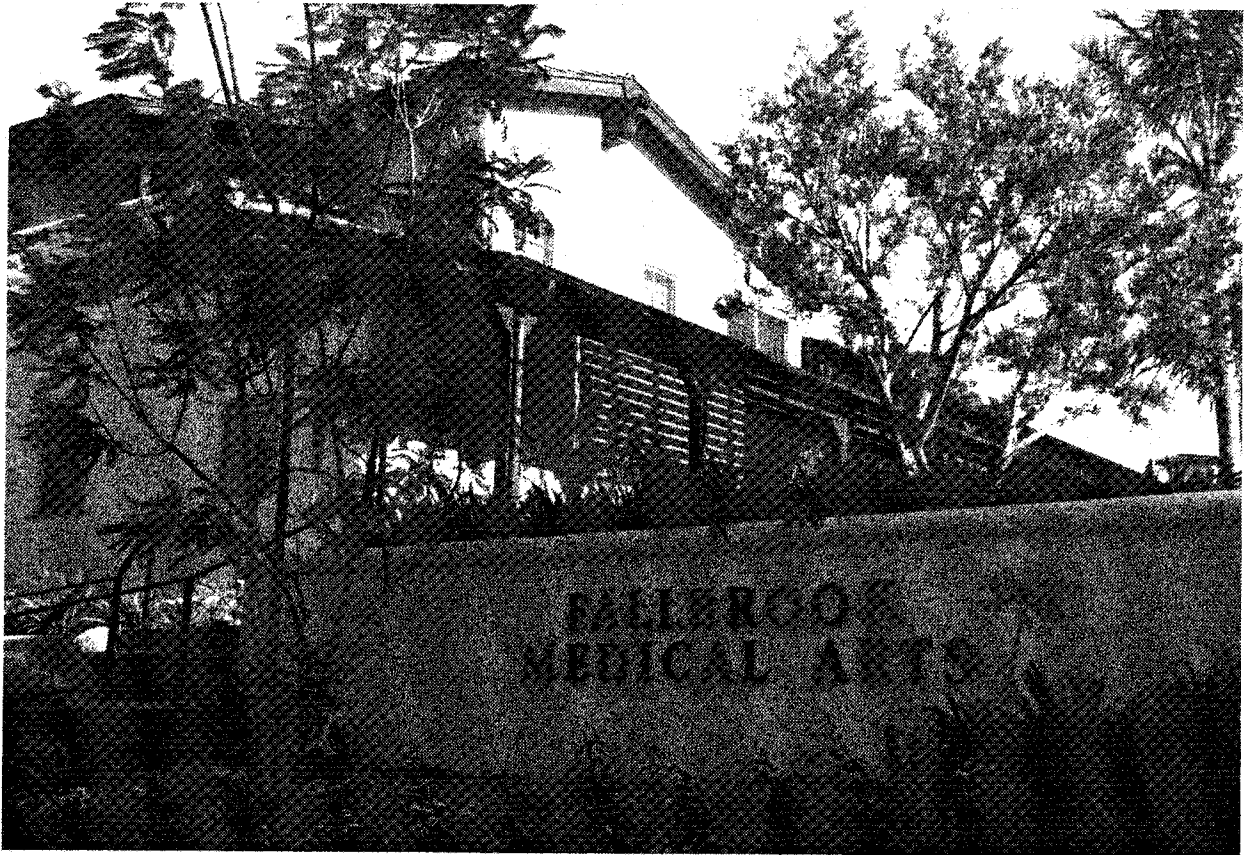



MAIN STREET IN THE TOWN CENTER

B1. COMMERCIAL DEVELOPMENT IN THE TOWN CENTER

INTRODUCTION

Fallbrook's Town Center is a key element of the community's identity and contact with history. The Town Center's character is created by several qualities which together form a charming pedestrian-oriented village center, much in the tradition of the classic American "Main Street."

The Town Center is located in the heart of the community and is made up of two basic sub-districts. Each sub-district has its own special characteristics which contribute to the overall atmosphere of the village.

The first sub-district (Guideline B1-A) is the oldest and most visible retail area in the Town Center. It fronts directly on Main Street and Mission Road beginning at Mission Road and Iowa Street on the northern end of the Town Center, and ends at Main Street and Elder Street on the southern end of the Town Center.

The second sub-district (Guideline B1-B) surrounds Main Street and Mission Road on adjacent side streets. This area is characterized by less intensive retail, commercial and office uses. This sub-district surrounds the retail spine of Main - Mission. It also includes commercially zoned property which extends east of Main Street along Alvarado Street.

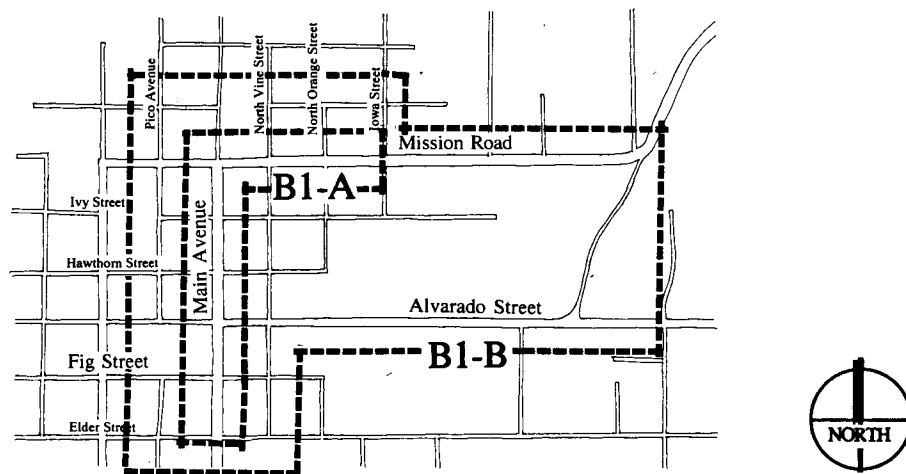

B1 - A
Main Street and
Mission Road Sub-District

B1 - B
Town Center Side Streets Sub-District

TOWN CENTER BOUNDARY MAP

B1-A. COMMERCIAL DEVELOPMENT IN THE TOWN CENTER MAIN STREET AND MISSION ROAD

- Maintain the “Street Wall” along Main Street and Mission Road.
- Encourage pedestrian activity and active building frontages.
- Maintain the continuity of the character of existing buildings.
- Locate parking lots away from street view.
- Plant street trees along building frontages.

This Guideline applies to all commercial development along Main Street and Mission Road in the Town Center.

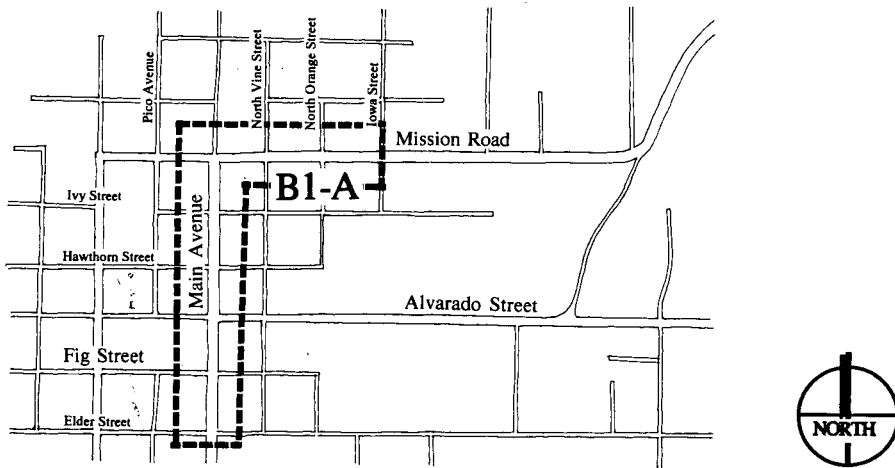

B1 - A
Main Street and
Mission Road Sub-District

1. SITE PLANNING

- Place as much of the front facade of buildings as possible on the front property lines to maintain the the continuity of the “Street Wall.” Pedestrian oriented spaces formed by architectural elements such as colonnades, arcades and trellises are encouraged. Courtyards and other recessed pedestrian spaces facing the street are also encouraged, but should be limited to a width of fifty percent of the building’s street facade. All other gaps in the street wall are discouraged.

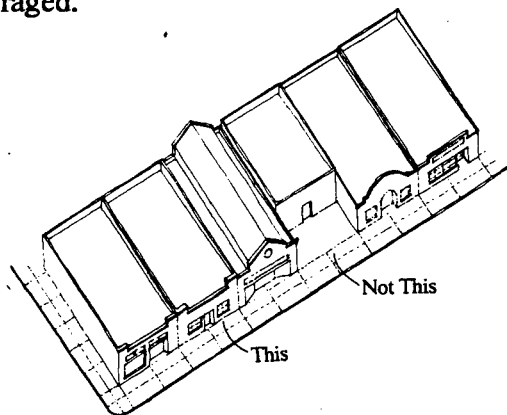

MAINTAIN THE “STREET WALL”

- Create active street frontages by locating retail shops and other pedestrian-oriented activities on the ground level at the street. Also, provide frequent building entrances along the street. Avoid locating blank walls, parking and other non-active uses along the street.

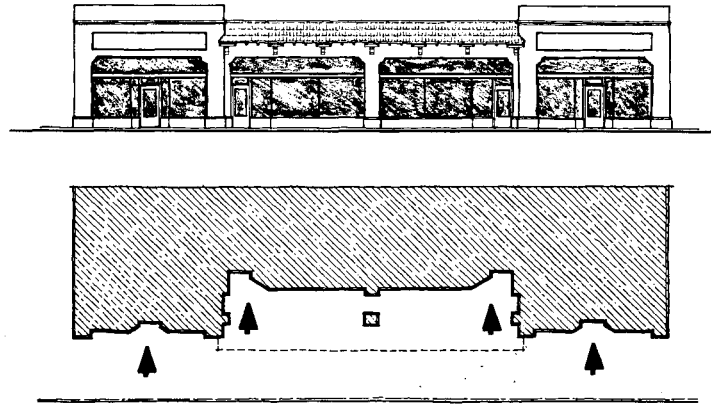

FREQUENT ENTRIES ENCOURAGED

2. PARKING AND DRIVEWAY ACCESS

a. Parking Lot Location

- Minimize the visual impact of parking facilities by locating them to the rear of the property.

b. Driveway Access

- Minimize curb cuts for driveways on Main Street and Mission Road. When curb cuts are necessary, reduce their width to a minimal dimension and minimize gaps in the street wall.
- Locate parking access points on alleys and side streets when possible. Properties which abut side streets should use only the side street for vehicular parking and service access. Driveways which occur off Main Street or Mission Road are encouraged to use architectural elements to reinforce the visual continuity of the street wall.

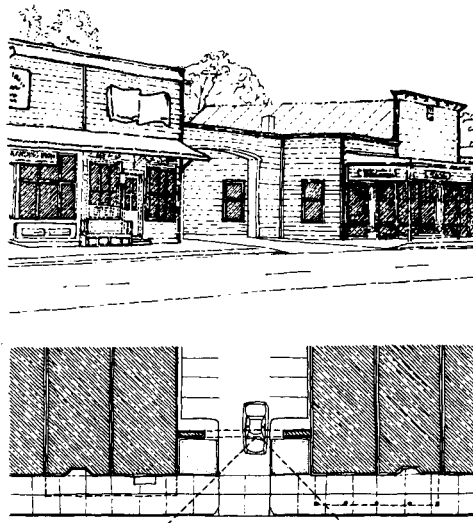

DRIVEWAY GATEWAY EXAMPLE

- The design of parking access drives should take into consideration pedestrian safety issues and should provide adequate vision for a driver to safely enter the street.

c. Parking Lot Setback and Planting

- When a parking lot must abut a public street, it should be setback at least 10 feet from the property line. The setback area should be planted with trees and shrubs following the same guidelines as specified in Sub-District B1-B: The Town Center Side Streets.
- Planting guidelines listed in Sub-District B1-B should also be followed for internal parking lot planting if the parking lot is over 6000 square feet. There are no planting or setback requirements for the interior property lines of parking lots in Sub-District B1-A.

3. ARCHITECTURAL CHARACTER

See Guideline A3. “Old and New Design Relationships” and Guideline A4. “Architectural Character.”

- In the Town Center, the street facades of single lot (usually 50 feet wide) buildings should be designed to be compatible with the scale, in height and width, of surrounding buildings.

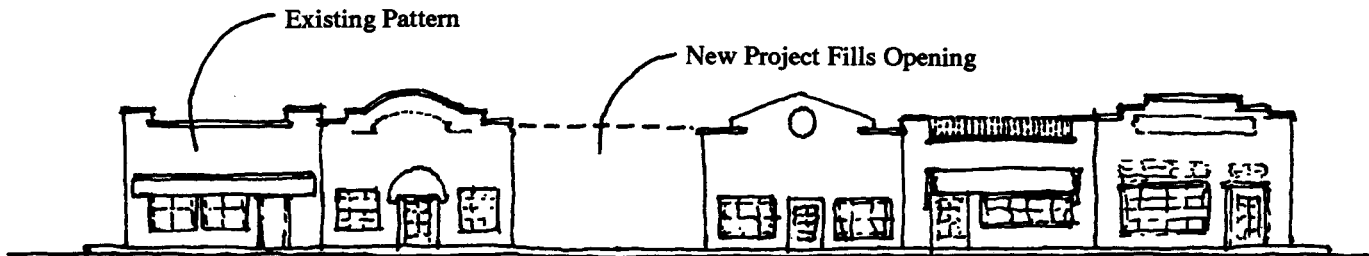

INFILL SENSITIVITY TO HEIGHT AND WIDTH OF NEIGHBORS

- To maintain the scale of the street in the Town Center, buildings over two stories are discouraged.
- At street level, buildings should have adequate clear glass to enable pedestrian views into retail shops and other spaces. In most instances there should be more glass than solid wall. Street level transparency should be balanced by more wall and less glass on the upper facade areas.

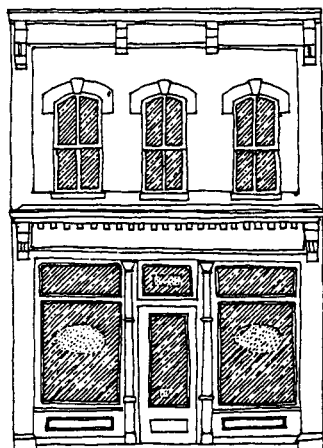

BALANCED TRANSPARENCY

- The street facades of buildings are encouraged to include forms or materials which place emphasis on the pedestrian entries.

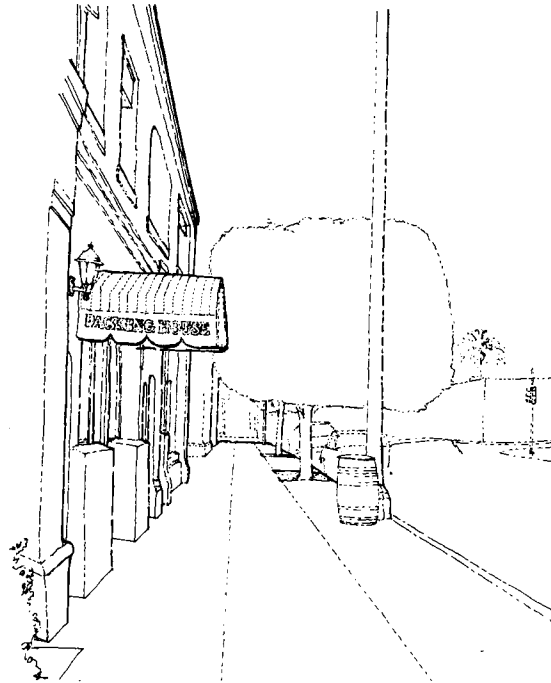

PEDESTRIAN ENTRY HIGHLIGHTS

- When the rear of a building is used as an entry or when it is visible from the street, give special attention to its design.
- In the Town Center, Main Street and Mission Road District, roof forms which are dominated by the facade so that they appear to be facing the street, like parapets and gable ends, are encouraged. If parapets are used, the upper area of the parapet should have a strong horizontal detail to provide a visual terminus of the building against the backdrop of the sky.

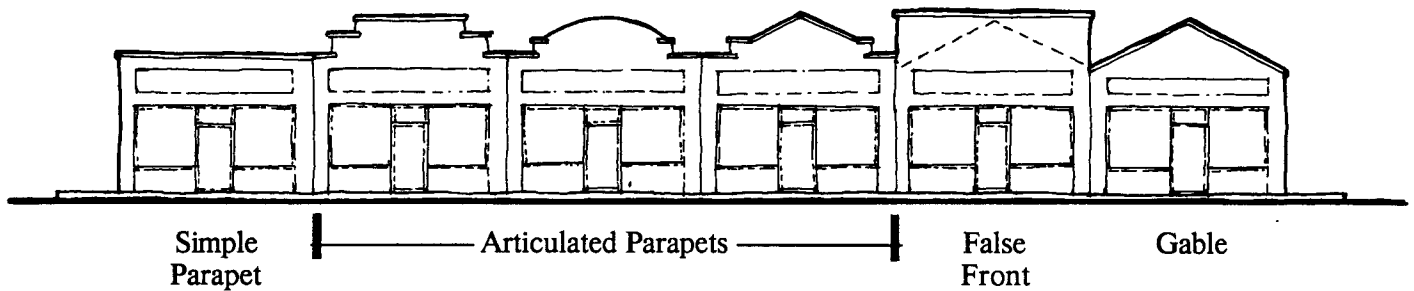

RECOMMENDED ROOF SHAPES IN THE TOWN CENTER

4. PLANTING GUIDELINES

a. Street Trees

• Street trees on Main Street and Mission Road should be planted within the sidewalks and protected from pedestrian foot traffic by an iron grate, or other treatment. Trees should be planted at an approximate spacing of 25 feet. Recommended Town Center trees include:

- *Agonis flexuosa* (Peppermint Tree)
- *Arbutus unedo* (Strawberry Tree)
- *Bauhinia variegata* (Orchid Tree)
- *Calodendron capense* (Cape Chestnut)
- *Geijera parviflora* (Australian Willow)
- *Pyrus calleryana* (Ornamental Pear)

b. Courtyards

• Courtyards, patios and other outdoor activity spaces are encouraged. Design of courtyards should consider:

- A choice of shaded and sunny areas.
- Variety of texture and color.
- Covered and uncovered outdoor passages.
- Ability to secure at night.

B1-B. COMMERCIAL DEVELOPMENT IN THE TOWN CENTER SIDE STREETS

- Maintain the pedestrian character on the Town Center side streets.
- Encourage pedestrian activity and usable pedestrian areas.
- Locate parking away from street view.

This Guideline applies to all commercial development on Town Center side streets.

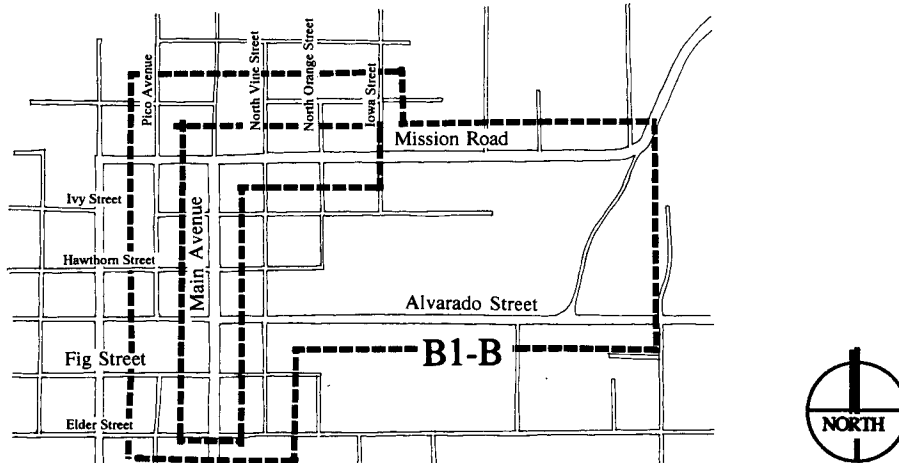

B1 - B
Town Center Side Streets Sub-District

1. SITE PLANNING

- Front yard setbacks are not required in this sub-district. When the front facade of a building is set back from the front property line, provide a pedestrian or planted area between the building and the street property line. Plazas and other pedestrian-oriented uses which are formed by architectural elements, such as colonnades, courtyards and trellises are encouraged.
- Planted side and rear yards are encouraged where they are not required by the Zoning Ordinance.
- Avoid locating blank walls, parking and other non-active uses along the street frontages.

2. PARKING LOTS AND DRIVEWAYS

a. Parking Lot Location

- Minimize the visual impact of parking facilities by locating them to the rear of the property. A less desirable location, if rear parking is not possible, is to locate the parking to the side of the buildings.
- Parking lots should be set back at least 10 feet from front or side street property lines, and 5 feet from rear and interior property lines.

b. Driveway Access

- Minimize the number of curb cuts for driveways.
- When curb cuts are necessary, reduce their width to a minimal dimension.
- Locate parking access points on alleys when possible. Properties which abut side streets should normally use the side street for parking and service access.

3. PLANTING GUIDELINES

a. Street Edge

- When a building is set back from the property line along a public street, the area between the building and property line shall be planted with at least 1 tree per 300 square feet of total area. Trees should be 15 gallon size minimum.

- **Parking Lot Setbacks**

Trees: Provide at least one tree per 300 square feet of total area between the parking lot and front or side street property line. Trees should be 15 gallon size minimum.

Shrubs: Shrubs and/or low walls should provide a visual screen of a minimum of 30 inches in height after 2 year's growth for at least 80 percent of the length of the parking area fronting a street, except where shrubs or walls will obstruct views of oncoming traffic. When walls are used, a minimum 5 foot wide planted buffer should be provided on the street-facing side of the wall. For shrubs in massed plantings, use "on center" dimensioning to space shrubs so that branches intertwine after two year's average growth.

b. Interior Property Line

- When side and rear yard areas are provided, they should be fully landscaped. Provide at least one tree per 300 square feet of total yard area. Trees should be 15 gallon size, minimum.

- **Parking Lot Setbacks**

Trees: Provide at least one tree per 100 square feet of total area between the property line and edge of the parking lot. Trees should be 15 gallon size, minimum.

Shrubs: Shrubs should provide a visual screen of a minimum of 30 inches in height after 2 years growth. For shrubs in massed plantings, use "on center" dimensioning to space shrubs so that branches intertwine after two year's average growth.

c. Internal Parking Lot Planting

- For all parking lots greater than 6000 square feet, in addition to all other guidelines, an internal area equivalent to a minimum of 5 percent of the total parking area should be planted with a combination of trees and shrubs. Tree spacing should be such that every designated parking space is within 30 feet of the trunk of a tree.
- The parking lot perimeter should terminate a minimum 5 feet from the face of a building. This area should be planted with a combination of trees and shrubs, unless used as a pedestrian walkway. Space may be decreased to a minimum of 2 feet of planted area between the parking lot and the building, if the location is not visible from a public street.

B2. COMMERCIAL DEVELOPMENT OUTSIDE THE TOWN CENTER

Unify commercial development outside the Town Center and integrate it into the community landscape, minimizing the impact of signs, parking lots and traffic congestion.

This Guideline applies to all commercial development located outside the Town Center as defined in Guideline B1.

1. SITE PLANNING

- Provide a minimum 15 foot deep Landscaped Street Edge Zone along all front and side street property lines. This zone should be composed of elements which will provide both a landscaped edge that is characteristic of Fallbrook's scenic roads as well as screening for parking and service areas. The Landscaped Street Edge Zone should only be interrupted by driveways, sidewalks or pedestrian areas. Parking is strongly discouraged in this location.
- To improve the pedestrian environment along commercial streets, building facades should be located on at least 30 percent of the property's principal street frontage. A higher percentage is encouraged when feasible. Place the building(s) against the Landscaped Street Edge Zone, parallel to the street.

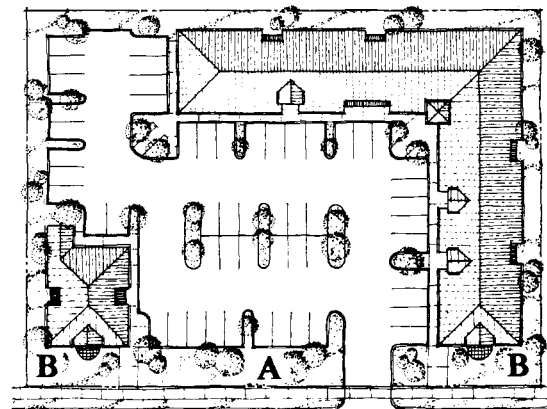

Street
30 PERCENT MINIMUM FRONTAGE

A. Landscaped Street Edge Zone
B. Building Facades Along The Landscaped Street Edge Zone

2. PARKING LOTS AND DRIVEWAYS

Refer to the San Diego County Zoning Ordinance Division 6750 and County of San Diego Offstreet Parking Manual for further requirements regulating driveway location.

- Minimize the number of curb cuts for driveways. The following schedule should be used as a guide:

<u>Parcel Street Frontage</u>	<u>Maximum Number and Width of Curb Cuts</u>
200' OR LESS	1 CURB CUT @ 25' WIDE or 2 CURB CUTS @ 15' WIDE EACH
201' OR MORE	2 CURB CUTS @ 25' WIDE FOR THE FIRST 201' AND 1 CURB CUT FOR EACH ADDITIONAL 200' OF FRONTAGE

- Shared or joint use driveways between separate properties are encouraged to reduce the number of curb cuts on public streets.
- Locate driveways as far from intersections as possible. On corner lots locate driveways as close to the interior side yard as possible.
- Parking lots should be set back at least 5 feet from rear and interior property lines. The setback area should be fully landscaped as outlined in Paragraph (3b) following.
- When abutting residential uses, a commercial parking lot should have a solid 6 foot high fence or wall within the interior side or rear yard planting area. Fences or walls should have a planted edge of no less than 4 feet between the face of the wall or fence and the parking lot.

3. PLANTING GUIDELINES

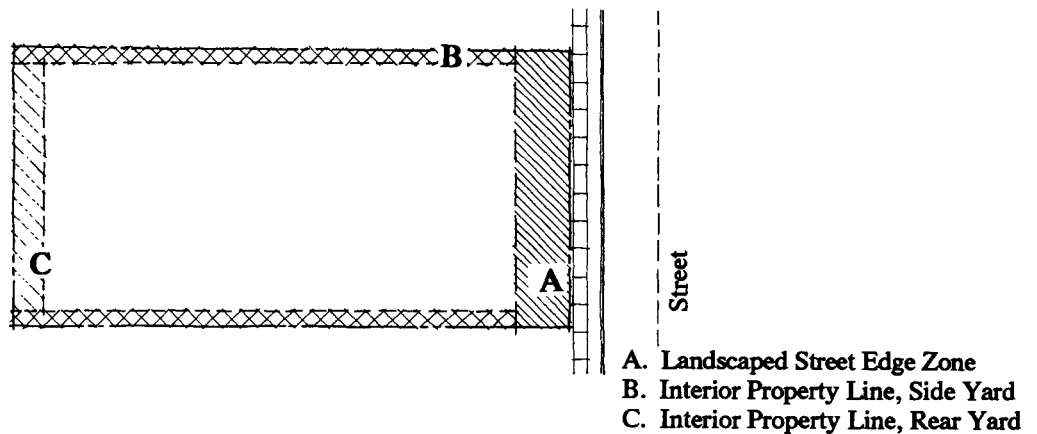

a. Landscaped Street Edge Zone

- The character of the Landscaped Street Edge should strongly reinforce the rural character of Fallbrook. This can be done with various trees and shrubs, low walls of native stone, wooden rail fences and natural features such as boulders and rock outcroppings.

Trees: Provide at least one tree per 300 square feet of the total area of the Landscaped Street Edge Zone. Trees should be a minimum size of 15 gallons.

Shrubs: Shrub plantings should be used to create spatial definition within the planting areas. Low, creeping shrubs may be used in the foreground; larger, coarser shrubs in the background. Blooming, fragrant shrubs are encouraged. Shrubs should be spaced with "on center" spacing so that branches intertwine after two years growth.

b. Interior Property Line

- Side and rear yard areas should be fully landscaped. Provide at least one tree per 300 square feet of total yard area. Trees should be 15 gallon size, minimum.

- **Parking Lot Setbacks**

Trees: Provide at least one tree per 100 square feet of total area between the property line and edge of the parking lot. Trees should be 15 gallon size, minimum.

Shrubs: Shrubs should provide a visual screen of a minimum of 30 inches in height after 2 years growth. For shrubs in massed plantings, use “on center” dimensioning to space shrubs so that branches intertwine after two year’s average growth.

c. Internal Parking Lot Planting

- For all parking lots greater than 6000 square feet, in addition to all other guidelines, an internal area equivalent to a minimum of 5 percent of the total parking area should be planted with a combination of trees and shrubs. Tree spacing should be such that every designated parking space is within 30 feet of the trunk of a tree.
- The parking lot perimeter should terminate a minimum 5 feet from the face of a building. This area should be planted with a combination of trees and shrubs, unless used as a pedestrian walkway. Space may be decreased to a minimum of 2 feet of planted area between the parking lot and the building, if the location is not visible from a public street.

B3. MULTI-FAMILY RESIDENTIAL DEVELOPMENT

The opportunity to create a sense of neighborhood exists in multi-family developments. Because neighborhoods contribute to the overall sense of community in Fallbrook it is important that multi-family developments incorporate features which enhance their neighborhood character.

- Orient as many dwelling units as possible toward the street.
 - Minimize the impacts of parking on the residential character of the street.
 - Provide useable open space.
 - Provide landscaping which enhances the feeling and scale of residential streets and properties.
-

1. SITE PLANNING

- Provide a minimum 20 foot planted Front Yard setback along all front and side street property lines. The setback area should be fully landscaped, interrupted only by driveways, sidewalks or pedestrian areas. Parking is strongly discouraged in this area.
- Right of way areas should be planted in a similar way as the front yard setback area, though the use of trees should be avoided.

2. STREET FRONTAGE

On all streets except major arterials, multi-family residential developments should emphasize a neighborly approach to street frontages.

- In order to promote the interaction of residents of multi-family buildings with their neighborhoods and minimize the separation of new residential projects within existing neighborhoods, developments should:
 - Organize as many of the dwelling unit entries as possible to front the street. The use of front porches or entry patios and terraces is highly encouraged..
 - Locate the first floor of living spaces at the ground floor level or not more than one-half story above ground level.



STREET FACADE ENTRIES

3. GROUP USABLE OPEN SPACE

- Provide all multi-family projects with at least 200 square feet of Group Useable Open Space per dwelling unit.
- The San Diego County Development Regulation governing Group Usable Open Space should apply, with the following additional recommendations:
 - Surfacing: concrete and asphalt are not recommended.
 - Location: a portion of the space should be located adjacent to the front yard set back, and no percentage of the required open space should be placed on the roof of a building.
 - Plantings should be provided to allow for shade, spatial definition, and aesthetic considerations.
 - Provide at least one designated childrens' play area of 400 square feet for the first 25 dwelling units. Add 100 square feet for each additional 25 dwelling units. One large play area is preferred to several smaller ones. This Guideline should be waived for senior citizen residential projects.

4. PRIVATE USABLE OPEN SPACE

- All multi-family projects should provide at least 100 square feet of Private Useable Open Space per dwelling unit.
- The County Development Regulation governing Private Usable Open Space should apply, with the following additional recommendations:
 - Private open spaces on the ground should be a minimum of 8 feet in each dimension and should be screened from public view by planting, a wall, privacy fence or other acceptable method.
 - Decks used for upper floor private open space should have a minimum dimension of 6 feet.
 - To provide open space on sloped sites, consider site terracing to achieve level spaces.
 - Open important living spaces such as living, kitchen and family rooms directly to outdoor spaces.
 - Locate private outdoor spaces to receive good sun penetration in winter months. Consider the use of deciduous trees to provide summer shade.

5. PARKING AND DRIVEWAY ACCESS

a. General Guidelines

- Residential parking lots should not be located between buildings and streets. Place parking lots the rear, side or at internal locations on the property.
- Garage doors of multi-family buildings should not face a public street, except when buildings are located on corner lots. In this case garage doors should open towards the side street only.
- Buildings which contain a common enclosed parking garage may orient one garage door opening toward the street.
- Carports and garages should be compatible with the architecture of the principal buildings.

- Views to parking areas should be screened from public streets, adjacent properties and Group Usable Open Spaces.

b. Parking Courts

- Surface parking lots, including carports, are encouraged to be designed as Parking Courts. A Parking Court is a double loaded driveway without through circulation. Its depth may be controlled primarily by fire department access regulations, but should not be over 10 parking spaces deep.

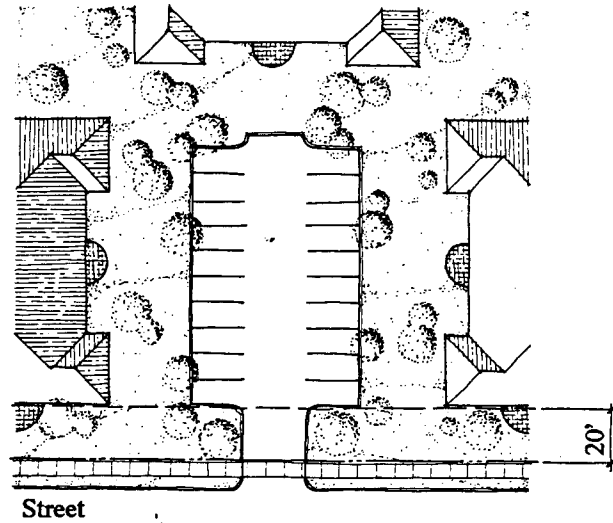

PARKING COURT

- Parking Courts should be set back from street property lines by a Planted Front Yard at least 20 feet deep.

c. Parking Drives

Parking drives are used for internal vehicular access to garages, carports, or open parking areas. They incorporate substantial areas for parking, normally perpendicular parking, along significant portions of their length, whether in garages, carports, or open parking.

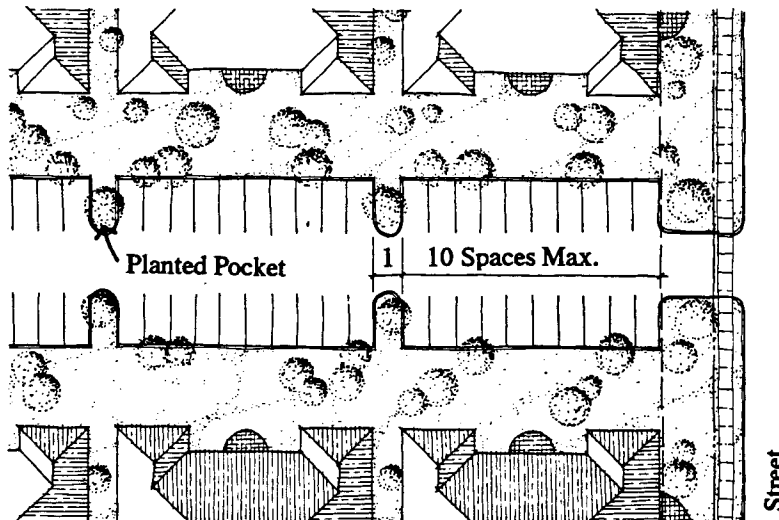

PARKING DRIVE

Long lines of parked cars or blank garage doors, unrelieved by planting areas or other types of screening is undesirable.

- Parking arranged in discrete bays to give a street-like character is encouraged. Each ten spaces of continuous perpendicular or angled parking should be separated from others by a planted pocket not less than one parking space wide. Architectural elements such as trellises, porches, or open stairways may encroach within these planted areas. Multiple garages that front parking areas or internal drives should have landscaped pockets between adjacent double garage doors.
- Planted “pockets” within parking areas should have at least one tree per “pocket.”
- In multi-family projects of over 50 dwelling units, the location of Parking Drives around the periphery of the project will tend to isolate a project from its surroundings. The extent of perimeter parking drives should be minimized in these large developments.

d. Covered Parking

- Covered parking areas, by means of garages, carports and trellised canopies, are strongly encouraged.
- For sloping sites, tuck under parking is often an economical solution that economizes in the use of the land.

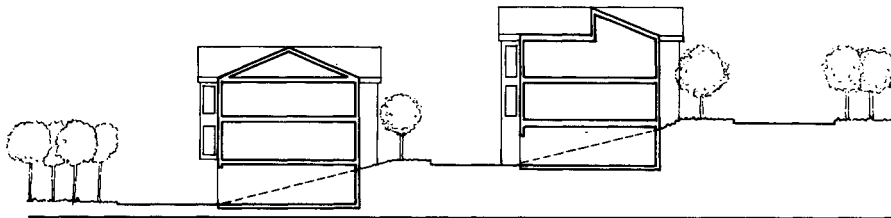

TUCK UNDER PARKING

6. PLANTING GUIDELINES

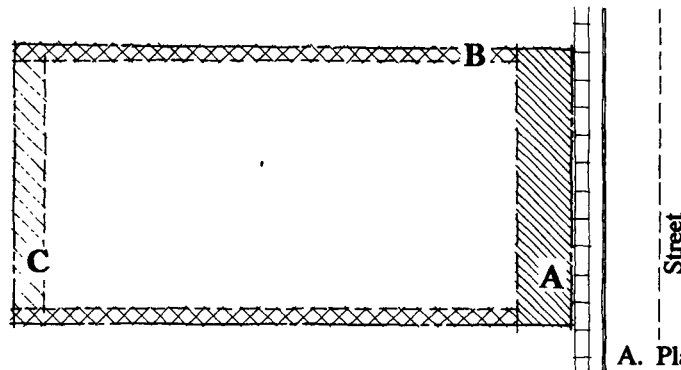

YARD PLAN

- A. Planted Front Yard With Street Trees
- B. Interior Property Line, Side Yard
- C. Interior Property Line, Rear Yard

a. Street Trees

- New public streets and private roads in residential developments should have street trees planted at regular intervals throughout the development. Trees should be planted on private property as close to the street or road as possible. The tree selected should reflect Fallbrook's existing landscape. Consult Appendix A. "Plant Selection Guide."

b. Planted Front Yard

- Parking lots should be set back from public streets by a Planted Front Yard of at least 20 feet in depth measured from the street facing property line.

- Planting Guideline for the Planted Front Yard:

Trees: Provide at least one tree per 300 square feet of yard area. Trees should be 15 gallon size, minimum.

Parking Lots: Shrubs and/or low walls should provide a visual screen of a minimum of 30 inches in height after 2 years growth. When walls are used, a minimum 5 foot wide planted buffer should be provided between the property line and the wall. For shrubs in massed plantings, use "on center" dimensioning to space shrubs so that branches intertwine after two year's average growth. At driveway entrances, shrubs and/or low walls should not obstruct views of oncoming traffic.

c. Interior Property Line Planting

- Provide a minimum 5 foot deep fully landscaped setback at all parking lot edges along the interior and rear property lines.

- Guideline for interior property line planting:

Trees: Provide at least one tree per 300 square feet of total area of the required side or rear yard. Trees should be 15 gallon size minimum.

Other Planting: Remaining areas of the side yard not covered by trees should be fully landscaped with shrubs and other carefully selected plant materials.

- Guideline for parking lot edges along interior property lines:

Trees: Provide at least one tree per 300 square feet of total yard area. Trees should be 15 gallon size, minimum.

Shrubs: Shrubs should provide a visual screen of a minimum of 30 inches in height after 2 years growth. For shrubs in massed plantings, use "on center" dimensioning to space shrubs so that branches intertwine after two year's average growth.

d. Internal Parking Lot Planting

- For all parking lots greater than 6000 square feet, in addition to all other guidelines, an internal area equivalent to a minimum of 5 percent of the total parking area should be planted with a combination of trees and shrubs. Tree spacing should be such that every designated parking space is within 30 feet of the trunk of a tree. Turf areas are discouraged.

- The parking lot perimeter should terminate a minimum 5 feet from the face of a building. This area should be planted with a combination of trees and shrubs, unless used as a pedestrian walkway. Space may be decreased to a minimum of 2 feet of planted area between the parking lot and the building, if the location is not visible from a public street.

7. MOBILE HOME PARKS

a. Intent

It is recognized that local regulation of mobile home parks is limited by provisions of state law. It is also recognized that it is impossible to anticipate locations. It is hoped that applicants for mobile home park developments will cooperate with the Community Planning Group and the Design Review Board in their review of Major Use Permit applications to conform the design as nearly as feasible to the following guidelines.

Mobile home parks should be built in such a way that they will be compatible with other buildings and developments. Mobile home parks provide a unique challenge to the developer and the Review Board because the majority of the individual homes are pre-fabricated. It is possible, however, for the homes to contribute to the character outlined by these Guidelines. It is also possible for the mobile home community as a whole to use elements of landscaping, lighting, signage, and architectural character in the community buildings to enhance the park's environment.

- Mobile homes in mobile home parks are encouraged to comply with the "Mobile Home On Private Lot Regulations", Sections 6502 through 6506 of the County Zoning Ordinance.
- Community buildings located within a mobile home park should meet the same architectural standards as buildings in the previous Guidelines.
- Landscaping, lighting, signage, off-street parking use the same Guidelines as outlined in the multi-family sections.

Consideration will be given by the Design Review Board to unique situations which may preclude following any of the Guidelines which are inappropriate because of the nature of mobile home development, however, the applicant should do everything possible to adapt the project to these Guidelines.

b. Individual Homes

Although a specific architectural character is not required for mobile homes, the following general principles should be followed:

- Exterior walls should have a natural wood appearance.
- Earth tones and warm, light colors are encouraged.
- Bright colored and highly reflective roof surfaces are discouraged. When necessary to place utilities on the roof, all visible surface equipment should be the same color as the roof itself.
- These Guidelines apply to carports and other outbuildings also.

B4. INDUSTRIAL DEVELOPMENT

- Provide a Landscaped Street Edge Zone
- Screen Roof Top Equipment, Storage Yards and Parking Lots

1. SITE PLANNING

- Provide a minimum 20 feet deep Landscaped Street Edge Zone along all front and side street property lines. The Landscaped Street Edge Zone should be composed of plantings, earth berms, and/or low walls. Storage yards, loading areas, parking, or similar uses are not permitted in this location.
- Pedestrian circulation and building location should be near the street side of the property. Where offices and similar small scale elements are part of the industrial development they should be oriented towards the street.
- Provide open space on the site for employee outdoor use, such as a place to have lunch.

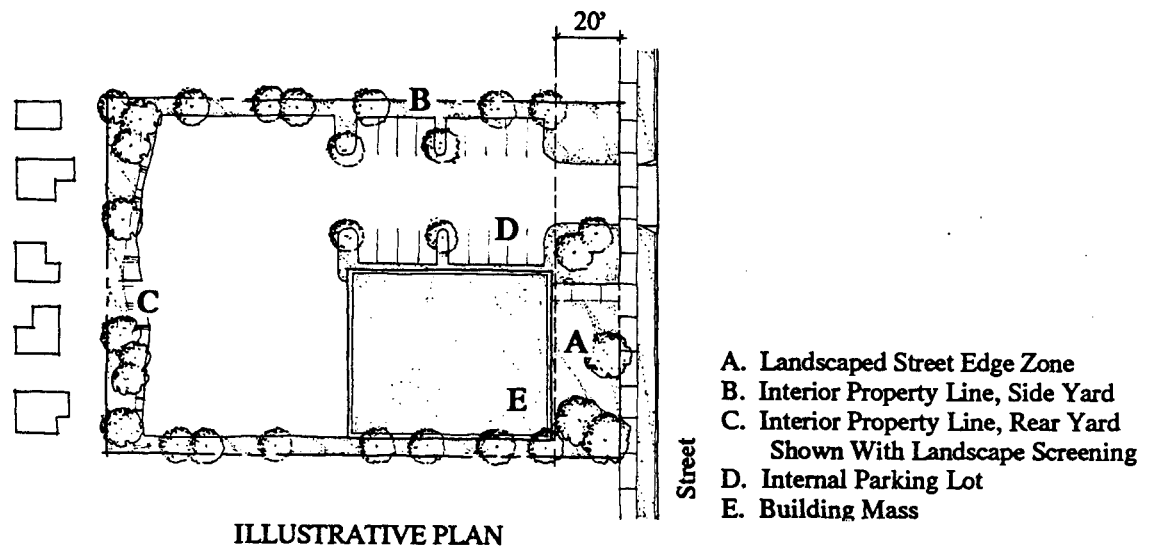

2. ARCHITECTURE

- Exterior wall materials that contain integral color and texture such as precast concrete, brick, split faced block and ribbed metal wall systems are encouraged. Bright colors and highly-reflective wall surfaces are discouraged. Earth-tones and warm, light colors are preferable.
- Locate entrances at street frontages when possible. Avoid placing long blank walls on the street .
- When long walls are necessary and are visible from off-site locations, provide visual relief through pilasters, reveals, color and material change, or small offsets in plan.

- Varying building heights and setbacks to define different functions such as offices and warehousing should be considered.
- Give careful attention to the appearance of large flat roof surfaces from off-site properties. If visible, built-up roofs should be accompanied by parapets; roof aggregate should be earth tone color and applied dense enough to completely cover the roof surface.
- Metal roofing systems with integral color (earth tone) are encouraged. Bright-colored and highly reflective roof surfaces, including unpainted galvanized metal roofing, are strongly discouraged.

3. SCREENING

- Storage yards and service areas should be screened from view using plantings alone or in combination with fences and walls.
- All fences and walls should be set back at least 20 feet from front and side street property lines.
- Roof top equipment should be screened from view. Where this is not possible due to grade changes, the roof top equipment should be enclosed in a housing which is sympathetic to the architecture of the main building; or it should be organized on the roof to give an orderly, uncluttered appearance with consideration for painting to match roof color. Due to the amount of roof top equipment that may exist in industrial projects it may be necessary to provide a roof top equipment layout plan for proper evaluation of roof top screening during the Design Review process.
- For all screening, special considerations should be made where changes in grade occur. If adjacent streets or neighboring properties are higher than the developing industrial site more stringent measures may need to be considered to accomplish the screening goal.

4. PLANTING GUIDELINES

a. Landscaped Street Edge Zone

- Planting Requirements for the Landscaped Street Edge Zone:

Trees: Provide at least one tree per 300 square feet of total area of the Landscaped Street Edge Zone. Trees should be 15 gallon minimum size. See Appendix A. "Plant Selection Guide."

Shrubs: Shrub planting should be used to create spatial definition within the planting area. Low, creeping shrubs may be used in the foreground, larger, coarser shrubs in the background.

When shrubs are used for screening they should provide a visual screen of a minimum of 5 feet in height after 2 years growth. Shrubs and walls should not obstruct views of oncoming traffic at driveways. For shrubs in massed plantings, use "on center" dimensioning to space shrubs so that branches intertwine after two year's average growth.

b. Interior Property Line

- Provide a minimum 5 foot deep fully landscaped setback area at all parking and service area edges along the rear and interior property lines.
- When abutting commercial or residential uses, industrial parking lots and service areas should have a solid 6 foot fence or wall separating the industrial use from the residential or commercial property. Fences or walls should have a planted edge of at least 5 feet between the face of the wall or fence and parking or service areas.
- Guideline for Interior Property Line Planting:

Trees: Provide at least one tree per 100 square feet of total area. Trees should be 15 gallon size, minimum.

Shrubs: Shrubs should provide a visual screen of a minimum of 5 feet in height after 2 years growth. For shrubs in massed plantings, use “on center” dimensioning to space shrubs so that branches intertwine after two year’s average growth.

c. Internal Parking and Service Areas

Where the total square footage of a parking or service area exceeds 6000 square feet, in addition to all other Guidelines, an internal area equivalent to a minimum of 5 percent of the total area should be planted with a combination of trees and shrubs.

C. GUIDELINES FOR AREAS WITH SPECIAL
ENVIRONMENTAL CONSIDERATIONS

C1. SCENIC ROADS

- Planted road edges are encouraged.
 - Established, dominate tree species should be repeated in future plantings along a scenic road edge.
 - Existing significant trees should be preserved whenever possible.
-

This Guideline applies to all projects subject to Design Review. For projects not subject to Design Review, it is strongly encouraged as a voluntary measure to preserve an important community resource. This Guideline pertains to the following scenic roads: Mission Road, Reche Road, Old Hwy. 395, Pala Road, Los Alisos Road, Fallbrook Street, Stage Coach Road, Gird Road, Live Oak Road, Pepper Tree Lane , Green Canyon Road, Wilt Road, Olive Hill Road, Sleeping Indian Road, De Luz Road.



LIVE OAK PARK ROAD

1. SITE PLANNING

- On Scenic Roads, building setbacks in excess of minimum requirements are encouraged.
- Low walls of native stone, wooden rail fences, boulders and native rocks are encouraged.

- Retain existing land forms, stream beds, mature trees, and important rock outcroppings. When possible, driveway and underground utilities should be located to avoid destruction of important natural features.

- **Planting guidelines:**

Trees: Where orchards predominate, orderly alignment of trees along the road edge is encouraged. Where rugged, native growth predominates, irregular alignment of trees along the road is encouraged. The goal is to reinforce the existing character of the road edge.

Shrubs: Shrubs exist in wild profusion beneath native trees along the scenic roads. Where native trees exist and new trees are going to be planted in irregular alignments, informal plantings of blooming shrubs as understory plants are encouraged. Shrubs do not exist in orchard conditions; therefore, where orchards predominate and new tree plantings are going to be orderly aligned, shrubs may be low and more subdued in flower color to duplicate the orchard condition.

2. GIRD ROAD, LIVE OAK ROAD, PEPPER TREE LANE

- These three roads are unique in that they have dominant tree species existing along the road edge. To maintain this consistency, plantings of Live Oaks (*Quercus agrifolia*) along the road edge are encouraged on Live Oak Road and Gird Road. Plantings of California Peppers (*Schinus molle*) are encouraged along the road edge on Pepper Tree Lane.

See Appendix A. "Plant Selection Guide", "Scenic Road Trees."

See Appendix A. "Plant Selection Guide", "Shrubs"

C2. HILLSIDE DEVELOPMENT

Hillside development should strive for:

- Sensitive siting of buildings.
 - Avoidance of buildings located on ridge lines.
 - Minimal grading and careful drainage.
 - Integrated streets and sidewalks.
 - Retention of existing trees.
 - Appropriate plantings for hillside and slope conditions.
-

This Guideline applies to all development subject to Design Review on hillside sites of 25% or more gradient.

1. SITING OF BUILDINGS

Most hillside sites are highly visible and will need extra attention given to their view from off-site locations in the community. The visual impact of all hillside development should be minimized, with buildings, retaining walls and other improvements deferring to the natural landforms and kept to as low a profile as possible. Development on ridgelines is strongly discouraged. The siting of buildings should avoid highly visible ridgeline locations and disturbance of natural landforms.

a. Reduction of the Visual Bulk of Structures

- Cut buildings into the hillside to reduce their visual bulk. Site buildings with different floor elevations to achieve height variation. Decks should be located low to the ground or on the roofs of lower levels of the building.

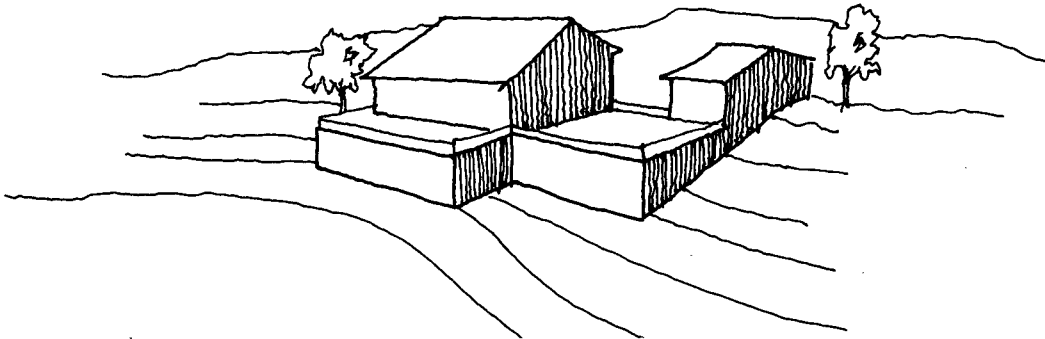

- Avoid large or long wall planes. Building masses should be broken into smaller-scale elements and elevations articulated to produce shadows through setbacks, overhangs, decks, recessed openings and projected windows.
- Roof lines should avoid extended horizontal lines and flat roofs. Pitched, gables and hipped roofs are more appropriate for hillside sites.

- Building forms should follow hillside slope to increase the integration of building and site. This is particularly important to roof forms.

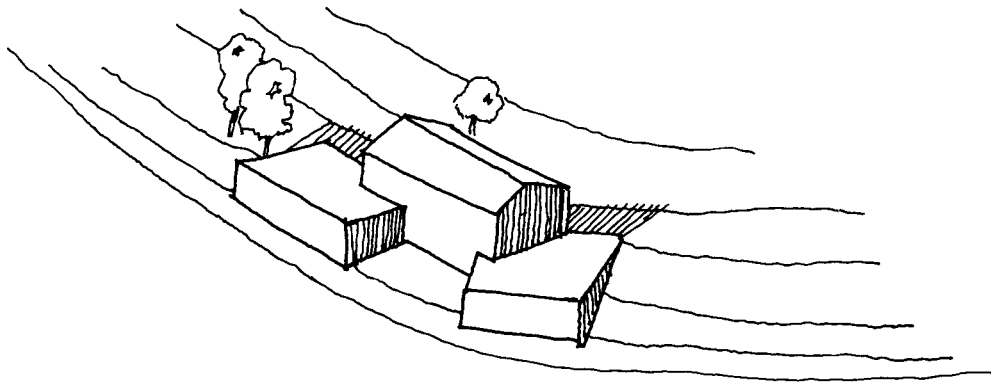

- Avoid massive roof overhangs and cantilevers on downhill faces of buildings.
- Avoid long and high retaining walls. When retaining walls are used, break them into smaller elements with planted terraces.

b. Materials and Color

The hillside, when seen as a whole, is a delicate pattern of buildings, open spaces and vegetation. No one building should stand out from others or from the natural landscape.

- All hillside dwellings should use materials and painted colors that approximate the range of colors in the natural landscape. Highly-saturated colors, highly-contrasting color combinations and reflective surfaces should be avoided. The use of earth toned paints, wood stained with medium earth tones, native stone, and earth tone colors of brick or textured block are encouraged.
- Earth tone tile or composition shingles are preferred roofing materials for hillside sites. If synthetic materials or built up roofs with gravel are used, they should be of medium earth tones. White gravel and highly-reflective roof surfaces are strongly discouraged.
- Glass, skylights and reflective materials such as aluminum and plastics must be used carefully to minimize their reflective properties. Dark anodized aluminum is encouraged when windows or other aluminum products are used. Large areas of glass should be protected by overhangs. Highly-reflective mirrored glass is strongly discouraged.

2. GRADING AND DRAINAGE

a. Slope Ratios

- In order to create slopes which closely reflect the surrounding natural hills, and to avoid the linearity of consistent slopes, graded hillsides should have variation in their slope ratios. Grading should minimize the "engineered" look of manufactured slopes. Avoid sharp cuts and fills--smooth, flowing contours of varied gradients from 2:1 to 5:1 are preferred.

- Slope banks can be softened by contoured grading of fill at the top and toe of the slope.

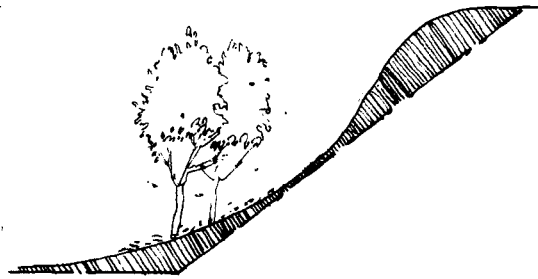
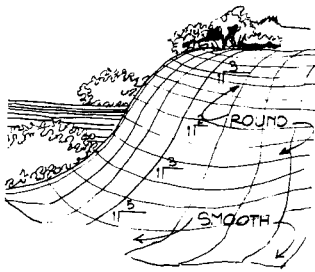

- Residential lots cut into existing slopes of 25 percent or greater, and a minimum elevation differential of 50 feet, or greater, should strive to have at least one-half of the lot remain at the gradient of the original slope.

b. Building Pads and Retaining Walls

- Hillside site design should avoid large building pads, large level open spaces, and should minimize the height of retaining walls. New building sites should be graded so that they appear to emerge from the slope.
- Retaining walls faced with local stone or of earth-colored and textured concrete are encouraged.

c. Drainage

- The community's natural landforms are an important part of its environment that should be respected in new development. Hillside grading should be minimized and designed to appear as close as possible to the surrounding land contours.
- Place drainage devices (terrace drains, benches and intervening terraces) as inconspicuously as possible on graded slopes. Natural swales leading downhill are good locations for downdrains. The side of a drain may be bermed to better conceal it.
- Concrete drains should be color-tinted to blend with natural soil color. Planting around drains is recommended to improve concealment.

3. STREETS AND WALKWAYS

The design of streets and walkways should work with the natural terrain and minimize cut and fill or hillsides.

- Street layout should follow existing natural contours so as to carefully integrate the street with the hillside.

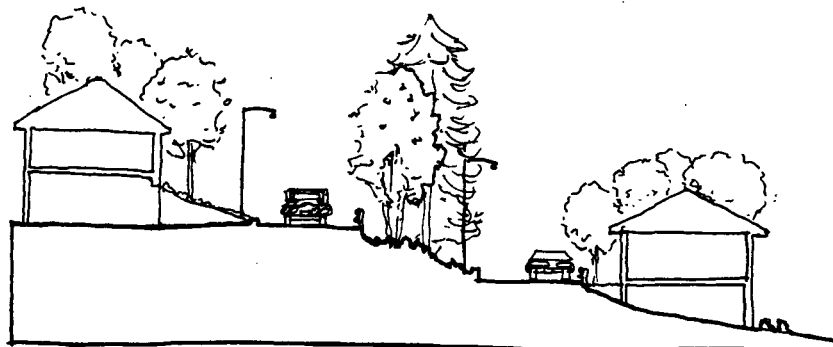

4. PLANTING DESIGN

a. Plant Selection

- Plant materials should be selected for their effectiveness of erosion control, fire resistance and drought tolerance.
- Hillside plant selection should consider neighbors' views and observe the following principles:
 - Where views have been established, follow downhill alignment of taller trees.
 - Use less dense, open trees that provide shade but do not block views.

b. Planting Techniques

- Use irregular plant spacing to achieve a natural appearance on uniformly graded slopes. Plant trees along contour lines in undulating groups to create grove effects which blur the distinctive line of the graded slope. Shrubs of varying height may be planted between tree stands. Ground covers of native and introduced species are appropriate for slope erosion control.
- When possible locate trees in swale areas to more closely reflect natural conditions and gather natural surface runoff for plant irrigation.

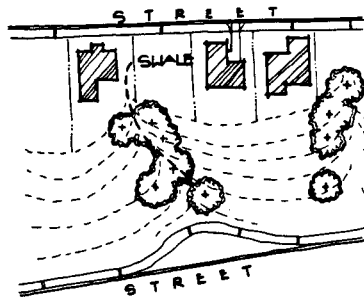

c. Transitional Slope Plantings

- Transitional slopes exist between the more ornamental plantings of newly planted areas and the native vegetation of undisturbed areas. The goal is to blend these two diverse areas together. The following planting principles are suggested for these areas:
 1. Establish the species of plants existing natively in the undisturbed areas.
 2. Determine the use of plants in the transitional areas: erosion control, shade, screening, etc.
 3. Select species from those already existing natively to fulfill the use requirements. Blend these plants into a planting plan of other hardy, drought resistant species of more ornamental or utilitarian qualities.
 4. As a general rule, encourage the planting of water-conserving plant species.
 5. Select low fuel volume plant materials.

d. Internal Slope Plantings

- Internal slopes exist within the newly developed project. They do not blend into native areas, as do transitional slopes, and, therefore, may be planted with a different type of plant palette. The following principles are suggested for internal slopes:
 1. Establish gradient of new slope and determine erosion control requirements.
 2. Fulfill erosion control needs with water-conserving plant material,
 3. As a general rule, encourage the planting of water-conserving plant species.
 4. Arrange plants in naturalized patterns, rather than regimented rows.

C3. DEVELOPMENT IN FLOOD PLAINS

The flood plains within Fallbrook encompass properties with substantial development potential.

The purpose of this Guideline is to define development standards and objectives that will minimize potential hazards of flood inundation and stream bank erosion while protecting the scenic and aesthetic value of the flood plain areas.

For further reference see the San Diego County Zoning Ordinance and Board of Supervisor's Policies I-68 and I-69 define development policies for Flood Plains.

The potential hazards created by development, grading and stream bank alteration within a Flood Plain are not only a concern of the development itself, but may cause damage to properties upstream and downstream of the property. For this reason, the larger off-site implications of all proposed buildings, other built improvements such as roads and parking areas, land form grading and stream bank alterations within a Flood Plain must be considered in all development reviews.

1. DEFINITIONS

- "100-YEAR FLOOD" means a flood estimated to occur on an average of once in 100 years.
- "FLOOD PLAIN" means a land area which is likely to be flooded, adjoining a river, stream, watercourse, ocean, bay or lake.
- "FLOODWAY" means the river channel and the adjacent land areas needed to carry the 100-year Flood, without increasing the water surface elevation more than one foot at any point. Additional criteria needed to provide good flow conditions may apply.
- "FLOOD FRINGE" means all land lying in the 100-year Flood Plain that is outside the Floodway.

2. FLOODWAY ZONE

- The defined Floodway zone should be kept as close as possible to its natural condition. Structures, parking areas and other major improvements are prohibited. Land form and stream bank alterations within the zone are strongly discouraged, except for the purpose of stabilizing stream bank areas with erosion problems.
- Construction of concrete or other engineered channels, dikes and levees within the Floodway zone is strongly discouraged and should only be used where flood damage to existing structures would be caused by flood flows.

3. DEVELOPMENT WITHIN THE FLOOD PLAIN

The general intent of this Guideline is to discourage development within the entire Flood Plain. Since this is sometimes not possible without a complete loss of property development potential, development in the Flood Fringe area is permitted subject to the following Guidelines:

a. Properties Partially within a Flood Plain

- For developments on properties with areas lying both within and outside of the Flood Plain, buildings should be clustered, to the maximum extent feasible, in the areas of the site lying outside the Flood Plain. Use of the Flood Plain as group open space for recreation or other activities which would leave it in a natural state is strongly encouraged.
- The intent of this paragraph should be observed in all new lot splits and Planned Developments. Required open spaces should be concentrated in the Flood Plain.

b. Properties Entirely within a Flood Plain

- If a development is proposed in the Flood Fringe area, the applicant must demonstrate the building, filling and other land form alterations will not contribute to off-site property damage by flooding, nor will it be subject to erosion by future floods.
- The finished floor level of all structures must be at least one foot above the 100-year Floodway elevation.

c. Structural Measures of Flood Control

- Dikes, levees and floodwalls may be used to protect existing structures but should not be used for new development, even in Flood Fringe areas. Instead, buildings should be located elsewhere or elevated above flood level.

4. STREAM BANK STABILIZATION

Self-formed stream channels tend to be in a state of equilibrium, nearly stable, and usually do not require artificial bank stabilization. Land use changes that cause an increase in impervious surfaces or sedimentation will result in channel enlargement and stream bank erosion. This may require measures to stabilize the stream bank.

- Stream rehabilitation is the least expensive and preferred method of stabilization, its objective being to maintain the natural characteristics of the watercourse. The process may include enlarging the channel at points of obstruction, clearing obstructions at natural bends and points of constriction, limitation of use in areas of excessive erosion and restoration of riparian vegetation.
- Concrete channels and other mechanical measures of stabilization are not permitted unless no other alternative exists.
- If stream bank stabilization other than stream rehabilitation and vegetative methods is required, hand-placed stone or rock riprap are the preferred methods.
 - a. Hand-placed rock may be used. The bank should be graded, before placing the stone, at a slope no greater than 2-1/2:1. The rock usually must be placed on a bed of gravel or crushed stone. This method is one of the most aesthetically acceptable stream protection measures.
 - b. Rock riprap forms a flexible protective lining which is not as susceptible to settlement and undercutting as rigid linings. Due to its roughness, it helps dissipate the stream's energy. The diameter of the rock should be sized to be stable under potential 100-year flood conditions with smaller stone filling the voids.

5. PLANTING IN THE FLOOD PLAIN

The Flood Plain should be kept as close as possible to its natural state. The large open spaces and indigenous riparian vegetation such as live oaks, sycamores and scrub should be preserved and emphasized in new plantings. Ornamental plantings and the introduction of non-native species should be avoided.

PART 4. DESIGN REVIEW APPLICATION REQUIREMENTS

This section lists submittal requirements for all projects subject to Design Review. Fifteen copies of all drawings must be submitted. All copies must be folded to fit an 8-1/2" x 11" envelope, unless they are so thick they can only be rolled up.

Please make submittals as clear as possible and follow accepted conventions of drawing--all drawings clearly labeled, scales shown, north arrow on plans, clear and readable line work.

Proposals should not be presented open-ended with expectations of the staff or Design Review Board to make decisions.

Additional information, drawings or other materials necessary to describe the project may be requested by Department of Planning and Land Use Staff or Design Review Board depending on the nature of the project or site.

Also, depending on the project's nature, not all of the above requirements may be needed - the applicant should discuss proposed modifications with the Planning staff member assigned to the community's Design Review.

The applicant may include additional information or materials such as sketches and models if they help explain the proposal. Photos of the site and neighboring properties are always required.

PRELIMINARY REVIEW

Development proposals that elect the optional step of Preliminary Review or a request for waiver may submit drawings or other materials appropriate to the nature of the project and extent of planning studies completed. In most cases, site design, location of buildings, grading, basic form and height of buildings and landscape concepts will be important. Building elevations, perspectives and other information may be presented, but kept in preliminary form.

SUBMITTAL REQUIREMENTS:

A. SITE ANALYSIS (of existing site conditions).

To enable evaluation of development proposals in relationship to existing conditions on the site, the following information must be presented on one or more drawings, accompanied by photographs and, if needed, written description.

1. Basic site information (locate on drawing): Site boundaries with dimensions; building setback lines and easements; existing streets, sidewalks and public rights-of-way; existing structures and other significant built improvements.
2. Existing natural features (locate on drawing):
 - Trees 6 inches or more in trunk diameter. Note trunk size and species.
 - Topography. Existing contours at 2 foot intervals with areas of slope over 25% highlighted.
 - Patterns of surface drainage, including location of dry and running streams, gullies, washes and natural swales.
 - Location of flood zone: locate floodway and 100-year flood plain.
 - Rock outcroppings greater than 8 feet in diameter measured at the ground. Include spot elevations to help visualize the mass of the rock outcropping.
 - Locate other significant natural features which are either site amenities or potential hazards in development.

3. Photographs of the site and neighboring environment: Provide photographs of the existing site and site conditions on adjacent properties within 400 feet of all site boundaries (including buildings on adjacent sites). Include photos of views to and outlooks from the site. Clearly label each photograph.

4. Summary. A brief written synopsis should summarize:

- Existing site amenities and assets.
- Special problems and dangers. Site areas in need of special consideration or to be avoided due to such problems as poor soil, drainage, steep slope, high water table, flood plain location.
- This synopsis may be noted on the Site Analysis drawing.

B. SITE PLAN

1. Boundaries and public improvements.

- Site boundaries, building setback lines, public streets and sidewalks (as proposed-include widths), other proposed public improvements (curbs, gutters, curb cuts).
- Include dimensions.

2. Streets, sidewalks and parking areas within the site:

- Include dimensions of parking areas and width of streets and sidewalks.
- Show location and label materials of areas of special paving such as walkways, courtyards, patios, and arcades.
- For parking areas show layout of spaces, areas of landscaping, dimensions of spaces and aisles, arrows indicating direction of flow. Number the parking spaces.

3. Structures.

- Location and dimensions with respect to lot lines.
- Include fences, walls and accessory buildings proposed. Give heights of fences and walls.

4. Show location of dumpsters and loading areas.

5. Grading and Drainage. This may be drawn on a separate plan at the option of the applicant. It should include:

- Existing and proposed contours at 2 foot intervals.
- Finished floor elevations of proposed structures.
- Indication of all water courses, with spot elevations of high and low points.
- Area of depth of cuts. Location and height of fills.
- Show retaining walls and adjacent spot elevations.

C. LANDSCAPE PLAN.

Show at same scale as Site Plan. This may be combined with the Site Plan (B) in the case of small projects.

1. Existing trees 6 inches or more in diameter with their proposed disposition (to be retained or removed). Give species and trunk diameter of each.

2. Location, species (give common and Latin name) and size (at planting - gallon or box size) of all new plant materials.

- Use symbols and a legend as necessary. Show all plant materials to scale.
- Ground cover may be indicated in mass.

3. Describe method of irrigation.
4. Describe means of erosion control, if applicable.

D. BUILDING FLOOR PLANS

E. BUILDING ELEVATIONS. Show all elevations.

- Note all finish materials on drawings.
- Provide color samples (paint chips) or one color board at the Design Review session.
- Dimension building heights from finish grade.
- Include exterior walls and fences with heights dimensioned.
- Show locations and sizes of building-mounted signs in building elevations.
- Show location of mechanical equipment, roof equipment, electrical transformers and solar panels in building elevations. Show means of screening roof equipment.

F. SECTIONS.

One sectional drawing is suggested at a suitable scale to show relationship of buildings to the site, public street and parking area. This item is optional.

G. SIGNS.

Provide a scaled drawing of each proposed sign with exterior dimensions and mounting height called out. Give total area of each.

- a. Draw or provide sample of letters and logos, and the full message to appear on the sign.
- b. Describe materials and colors of background and letters.
- c. Give means of illumination and magnitude of illumination.

H. LIGHTING.

Provide a site lighting plan with location, type, fixture height, power rating and shielding methods indicated. Show elevation drawing or manufacturer's photo of each fixture, including its material and color.

H. STATISTICAL SUMMARY.

Provide a written summary:

- a. Site areas. Total area of site, area-covered by buildings, area covered by parking lots and driveways, net area of site landscaping. All in square feet.
- b. Buildings. Total enclosed building area. If a residential project give number of units and development density (units/acre).
- c. Number of parking spaces required and proposed.
- d. This information may be noted on the site plan drawing.

Appendix A

Plant Selection Guide

The shrubs and trees listed within this Appendix reflect the design goals stated in A5. "Landscape Character." They are listed by zones, Commercial, Industrial, etc., and may be used throughout the site in the specified zone. Other shrubs and trees not listed here may also accomplish the desired goals, and if they do so, are encouraged also. Appendix B is more specific with regard to trees on significant streets in Fallbrook.

To use this Appendix, find the zone applicable to the project by reading across the upper line. Then read down to find plants appropriate for use in that zone. Please consult Sunset's Western Garden Book for additional information about each plant.

First is a Shrub Matrix. The majority of shrubs are listed by their genus names only, for instance, "Calliandra species". Over 250 different species exist within this genus and all are encouraged for use in Fallbrook, depending upon availability. To determine which species is appropriate for the intended use, consult Sunset's Western Garden Book finding the species listed under the genus name, "Calliandra". In one case, *Heteromeles abutilifolia*, *Toyon*, the species name and the common name are given in the Appendix. Only this species of *Heteromeles* is to be used.

Size considerations are defined for shrubs: low creeping varieties, which can be used for shrubby ground covers, medium sized, and large sized which can be used for screening, accents and spatial definition. All shrubs are considered to be low water using. Planting locations frequently determine tenderness to frost. Shrubs beneath trees, against walls, etc. are protected; whereas, shrubs in the open are vulnerable. The *Ribes* and *Rhus* species have deciduous habits; all other shrubs are evergreen. *Nerium oleander* has toxic foliage, but is included in the Appendix because of its other excellent qualities. Its use is encouraged where toxic foliage will not present a hazard,

Next listed are Low Fuel Volume Shrubs for use along rural roads where fire hazard exists. All of the shrubs are low growing and can exist with little or no summer water.

The last list is a Site Tree Matrix. Unlike the Shrub Matrix, the Site Tree Matrix lists the majority of tree names by genus and species, adding also the common name. This has been done because very specific trees are encouraged in Fallbrook. Where more than one species is desirable, the genus name is listed only. Additional considerations given for trees are low water use, frost resistance to 25 degrees, and evergreen leaf quality. Consideration of these characteristics may be important for a given location.

SHRUB MATRIX

Botanical Name	Low	Medium	Large	Scenic Roads	Com-mercial	Ind-ustrial	Parking Lot	Multi-Family	Town Center
Calliandra species		•	•	•	•	•	•	•	•
Ceanothus species	•	•	•	•	•	•	•	•	•
Grevillea noellii <i>No Common Name</i>		•		•	•	•	•	•	•
Heteromeles arbutifolia <i>Toyon</i>			•	•	•	•	•	•	
Lantana species	•	•	•	•	•	•	•	•	•
Juniperus species	•	•	•	•	•	•	•	•	•
Mahonia species	•	•		•	•	•	•	•	•
Melaleuca species			•	•	•	•	•	•	
Nerium oleander varieties		•	•	•	•	•	•	•	•
Ornamental grasses	•			•	•	•	•	•	•
Pittosposum species	•	•	•	•	•	•	•	•	•
Photinia species		•	•	•	•	•	•	•	•
Pyracantha species	•	•	•	•	•	•	•	•	•
Raphiolepis species		•	•	•	•	•	•	•	•
Ribes species	•	•	•	•	•	•	•	•	•
Rhus species			•	•	•	•	•	•	•

LOW FUEL VOLUME SHRUBS

Native Plants

Eriophyllum species, Yarrow
 Eschscholzia californica, California Poppy
 Lotus scoparius, Deerweed
 Lupinus species, Annual Lupine
 Mimulus species, Monkey Flower
 Salvia columbariae, Chia
 Salvia sonomensis, Creeping Sage
 Zauschneria species, California Fuchsia

Introduced Plants

Atemisia caucasica, Silver
 Atriplex glauca, Saltbush
 Atriplex semibaccata, Creeping Saltbush
 Cistus crispus, Rockrose
 Cistus salviifolius, Sageleaf Rockrose
 Santolina virens, Green Santolina

TREE MATRIX

Botanical Name Common Name	Low Water Use	Frost Resist.	Ever- green	Scenic Roads	Com- mmercial	Ind- ustrial	Parking Lot	Multi- Family	Town Center
Acacia decurrens <i>Green Wattle</i>	•	•	•	•	•		•		•
Agonis flexuosa <i>Peppermint Tree</i>	•		•				•		•
Albizia julibrissin <i>Silk Tree</i>	•	•		•	•	•			
Arbutus unedo <i>Strawberry Tree</i>	•	•	•	•	•				•
Bauhinia variegata <i>Orchid Tree</i>	•				•		•	•	•
Brachychiton acerifolius <i>Flame Tree</i>	•	•		•	•	•			
Callistemon species <i>Bottlebrush</i>	•	•	•	•	•	•	•	•	
Calodendron capense <i>Cape Chestnut</i>	•			•	•	•	•	•	•
Cassia leptophylla <i>Gold Medallion Tree</i>	•				•	•			
Ceanothus "Ray Hartman" <i>California Lilac</i>	•		•				•		
Cinamomum camphora <i>Camphor Tree</i>	•	•	•		•	•	•		
Eucalyptus lehmanii <i>Bushy Yate</i>	•	•	•			•	•		
Eucalyptus leucoxylon <i>White Ironbox</i>	•	•	•	•	•	•		•	
Euc. leucoxylon macrocarpa <i>Red Flowering Gum</i>	•	•	•	•	•	•		•	
Eucalyptus nicholli <i>Peppermint Gum</i>	•	•	•	•	•	•	•	•	
Eucalyptus sideroxylon <i>Red-iron Bark</i>	•	•	•	•	•	•	•	•	
Geijera parviflora <i>Australian Willow</i>	•	•	•				•		•

TREE MATRIX (cont.)

Botanical Name Common Name	Low Water Use	Frost Resist.	Ever- green	Scenic Roads	Com- mercial	Ind- ustrial	Parking Lot	Multi- Family	Town Center
Ginko biloba <i>Madenhair Tree</i>	•	•		•	•	•		•	
Jacaranda arcutifolia <i>Jacaranda</i>	•	•		•	•	•	•	•	
Koelreuteria species <i>Rain Tree</i>	•			•	•	•	•	•	
Olea eurpoaea <i>Olive Tree</i>	•	•	•	•	•	•	•		
Pinus halepensis <i>Allepo Pine</i>	•		•	•		•			
Pinus pinea <i>Italian Stone Pine</i>	•	•	•			•	•		
Pistache chinensis <i>Pistache Tree</i>	•	•		•	•		•	•	
Platanus acerfolia <i>Plane Tree</i>	•	•		•	•	•	•	•	
Prunus blireiana <i>Purple-leaf Plum</i>	•	•			•				
Pyrus callyana "Bradford" <i>Ornamental Pear</i>	•	•			•		•	•	•
Quercus agrifolia <i>Coast Live Oak</i>	•	•	•	•		•			
Rhus lancea (male trees) <i>African Sumac Tree</i>	•	•		•	•		•		
Robinia pseudoacacia var. <i>Black Locust</i>	•	•		•	•	•		•	
Schinus molle <i>California Pepper</i>	•	•	•	•	•	•		•	
Sophora japonica <i>Japanese Pagoda Tree</i>	•	•		•	•	•		•	
Tabebuia species <i>Trumpet Tree</i>	•	•		•	•		•	•	